

SURFboard®

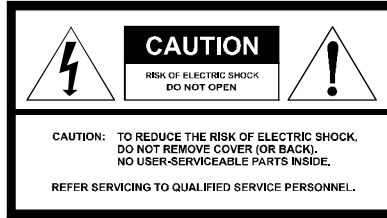

SB2100D Cable Modem

Installation Manual





Graphical symbols and supplement warning marking locations on the bottom of the appliance.

	This symbol indicates that dangerous voltage levels are present within the equipment. These voltages are not insulated and may be of sufficient strength to cause serious bodily injury when touched. The symbol may also appear on schematics.
	This symbol calls attention to a critical procedure, or means refer to the instruction manual for opening or service information. Only qualified service personnel are to install or service the equipment. The symbol may also appear in text and on schematics.

WARNING:

TO PREVENT FIRE OR SHOCK HAZARD, DO NOT EXPOSE THIS APPLIANCE TO RAIN OR MOISTURE.

CAUTION:

TO PREVENT ELECTRICAL SHOCK, DO NOT USE THIS PLUG WITH AN EXTENSION CORD, RECEPTACLE, OR OTHER OUTLET UNLESS THE BLADES CAN BE FULLY INSERTED TO PREVENT BLADE EXPOSURE.

Canadian Compliance: This Class B digital apparatus meets all requirements of the Canadian Interference-Causing Equipment Regulations. Cet appareil numérique de la classe B respecte toutes les exigences du Règlement sur le matériel brouilleur du Canada.

Repairs: If repair is necessary, call the General Instrument Repair Facility at 1-800-227-0450 for a Return for Service Authorization (RSA) number before sending the unit. The RSA number must be prominently displayed on all equipment cartons. Pack the unit securely, enclose a note describing the exact problem, and a copy of the invoice that verifies the warranty status. Ship the unit PRE-PAID to the following address:

General Instrument Corporation
Attn: RSA # _____
5964 E. 14th Street
Brownsville, TX 78521

NOTE TO CATV SYSTEM INSTALLER: This reminder is provided to call CATV system installer's attention to Article 820-40 of the NEC that provides guidelines for proper grounding and, in particular, specifies that the cable ground shall be connected to the grounding system of the building, as close as possible to the point of cable entry as practical.

Copyright © 1999 by General Instrument Corporation.

All rights reserved. No part of this publication may be reproduced in any form or by any means or used to make any derivative work (such as translation, transformation or adaptation) without written permission from General Instrument.

General Instrument reserves the right to revise this publication and to make changes in content from time to time without obligation on the part of General Instrument to provide notification of such revision or change. General Instrument provides this guide without warranty of any kind, either implied or expressed, including, but not limited, to the implied warranties of merchantability and fitness for a particular purpose. General Instrument may make improvements or changes in the product(s) described in this manual at any time.

General Instrument SURFboard is a registered trademark and the General Instrument logo is a trademark of General Instrument Corporation.

Macintosh is a registered trademark of Apple Corporation.

Netscape is a registered trademark of Netscape Communications Corporation.

OpenView is a registered trademark of Hewlett-Packard Company.

Solaris is a trademark of Sun Microsystems, Inc

UNIX is a registered trademark of the Open Group.

Windows and Windows NT are trademarks of Microsoft Corporation.

Contents

Section 1

Introduction

Using This Manual	1-2
Document Conventions	1-2
If You Need Help	1-2
Calling for Repairs	1-3

Section 2

Overview

Front Panel	2-2
Rear Panel	2-3

Section 3

Installation and Operation

Before You Begin	3-1
Installing a Single User	3-2
Installing Multiple Users	3-3
Powering Up the First Time	3-3
Configuring the Computer	3-4
TCP/IP	3-4
IP Address	3-9
Setting the Frequency	3-10
Configuring your System for Telco Return Mode	3-12
TFTP Configuration File	3-12
Upgrading the Firmware	3-13
Upgrading the SB2100D Over the Cable Network	3-13
Upgrading the SB2100D Using SNMP	3-14

Section 4
HTML User Interface

Section 5
Troubleshooting

Appendix A
Specifications

Downstream A-1
 Upstream A-1
 General A-1

Appendix B
Event Log Messages

Event Message Format..... B-1
 Priority Levels..... B-1
 Predefined log messages B-2
 SB2100D Specific Log Messages B-6

Figures

Figure 1-1 SB2100D front panel 1-1
 Figure 2-1 SB2100D data path 2-1
 Figure 2-2 SB2100D front panel 2-2
 Figure 2-3 Rear panel connections 2-3
 Figure 3-1 Cable connections..... 3-2
 Figure 3-2 Multiple user connections..... 3-3
 Figure 3-3 Network window 3-5
 Figure 3-4 Network Component Type window 3-6
 Figure 3-5 Select Network Protocol window..... 3-6
 Figure 3-6 Network window with TCP/IP selected 3-7
 Figure 3-7 TCP/IP Properties window..... 3-8
 Figure 3-8 Run dialog box..... 3-9
 Figure 3-9 IP Configuration window 3-9
 Figure 3-10 Configuration Window 3-11
 Figure 3-11 Sample TFTP boot-file listing 3-13
 Figure 3-12 Configuration Manager Help..... 3-15
 Figure 4-1 Configuration Manager Help window 4-2
 Figure 4-2 Configuration Manager Startup window 4-3

Figure 4-3 Configuration Manager Signal window 4-4

Figure 4-4 Configuration Manager Addresses window 4-5

Figure 4-5 Configuration Manager Phone Window 4-6

Figure 4-6 Configuration Manager Phone Setup window 4-7

Figure 4-7 Configuration Manager Logs Window 4-8

Tables

Table 2-1 Front-panel LEDs 2-2

Table 2-2 Rear-panel connections 2-3

Table 5-1 Troubleshooting guidelines 5-1

Table 5-2 Troubleshooting checklist 5-2

Table B-1 Priority level B-1

Section 1

Introduction

The General Instrument SURFboard® SB2100D dual-mode cable modem provides the link from the home or business computer to a high-speed DOCSIS-compliant data network. This network provides a downstream data-transfer rate up to 38 Mbps in a single 6 MHz channel using 64 and 256 QAM technology. A DOCSIS RF return path provides up to 10 Mbps using QPSK and 16 QAM.

The SB2100D features:

- One or two way operation
- Remote management through SNMP
- Automatic configuration and address assignment
- Software upgrades over the network
- Compatibility with PCs, Macintosh, and UNIX® operating system computers running TCP/IP protocol
- Extensive event logs for troubleshooting

Figure 1-1
SB2100D front panel

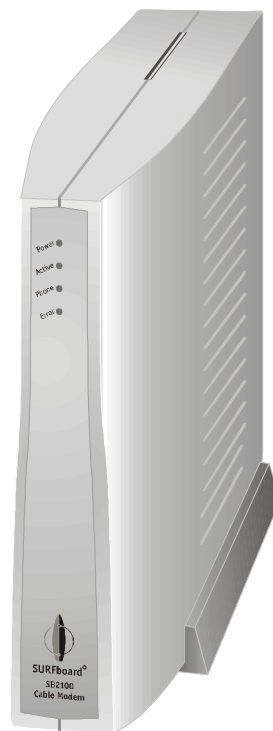

Using This Manual

The following sections provide information and instructions to install, configure and operate the SB2100D.

Section 1	Introduction provides a product description, the technical helpline, and repair/return information.
Section 2	Overview describes the functions of the SB2100D and identifies the front-panel LEDs and the rear-panel connectors.
Section 3	Installation provides instructions on how to install the SB2100D.
Section 4	HTML User Interface provides information on the user interface windows.
Section 5	Troubleshooting provides troubleshooting tips.
Appendix A	Specifications provides the technical specifications for the SB2100D.
Appendix B	Events Log Messages provides a description of the format and field codes of the diagnostic events log.
Abbreviations and Acronyms	The Abbreviations and Acronyms list contains the full spelling of the short forms used in this manual.

Document Conventions

Before you begin using the SB2100D, familiarize yourself with the stylistic conventions used in this manual:

Bold type	Indicates text that you must type exactly as it appears or indicates a default value
SMALL CAPS	Denotes silk screening on the equipment, typically representing front- and rear-panel controls and input/output (I/O) connections, and LEDs
Italic type	Denotes a displayed variable, a variable that you must type, or is used for emphasis
KEY+KEY	Key combinations indicating that you hold down the first key and then press the second key
Courier font	Indicates text displayed on a graphical user interface (GUI)

If You Need Help

If you need assistance while working with the SB2100D, call the General Instrument Technical Response Center (TRC) at **1-888-944-HELP (1-888-944-4357)**. The TRC is open from 8:00 AM to 7:00 PM Eastern Time, Monday through Friday. When the TRC is closed, emergency service *only* is available on a call-back basis.

When contacting the TRC from outside the United States, call the main switchboard number, **1-215-323-1000**, and ask for extension **4200**.

Calling for Repairs

If repair is necessary, call the General Instrument Repair Facility at **1-800-227-0450** for a Return for Service Authorization (RSA) number before sending the unit. The RSA number must be prominently displayed on all equipment cartons. The Repair Facility is open from 8:00 AM to 5:00 PM Central Time, Monday through Friday.

When calling from outside the United States, use the appropriate international access code and then call **956-541-0600** to contact the Repair Facility.

When shipping equipment for repair, follow these steps:

- 1 Pack the unit securely in the original shipping carton, if possible.
- 2 Enclose a note describing the exact problem. Enclose a copy of the invoice that verifies the warranty status.
- 3 Ship the unit **PREPAID** to the following address:

General Instrument Corporation

Attn: RSA # _____

5964 E. 14th Street

Brownsville, TX 78521

Section 2 Overview

The SB2100D cable modem delivers digital multimedia content in either a one or two-way transmission system. It provides access to a data network running over the cable system, which provides access to the worldwide web.

The SB2100D is authorized by the Cable Modem Terminations System (CMTS) for use on the network and automatically configures itself with the parameters received from the CMTS or headend. When the SB2100D is powered on, it scans the frequency spectrum to locate the data frequency and then automatically locks on to that channel. After finding the data channel, it searches for a message containing the upstream parameters such as frequency, modulation, symbol rate and forward error correction (FEC) format. The SB2100D then transmits a message to the CMTS requesting additional information that enables network connection. Through a series of messages, the SB2100D establishes Internet Protocol (IP) connectivity using Dynamic Host Configuration Protocol (DHCP) and then receives a configuration file using Trivial File Transfer Protocol (TFTP). This configuration file contains additional parameters that are required by the SB2100D. When the configuration is complete, the SB2100D registers with the CMTS and is authorized to use the network.

Figure 2-1 illustrates SB2100D data path:

Figure 2-1
SB2100D data path

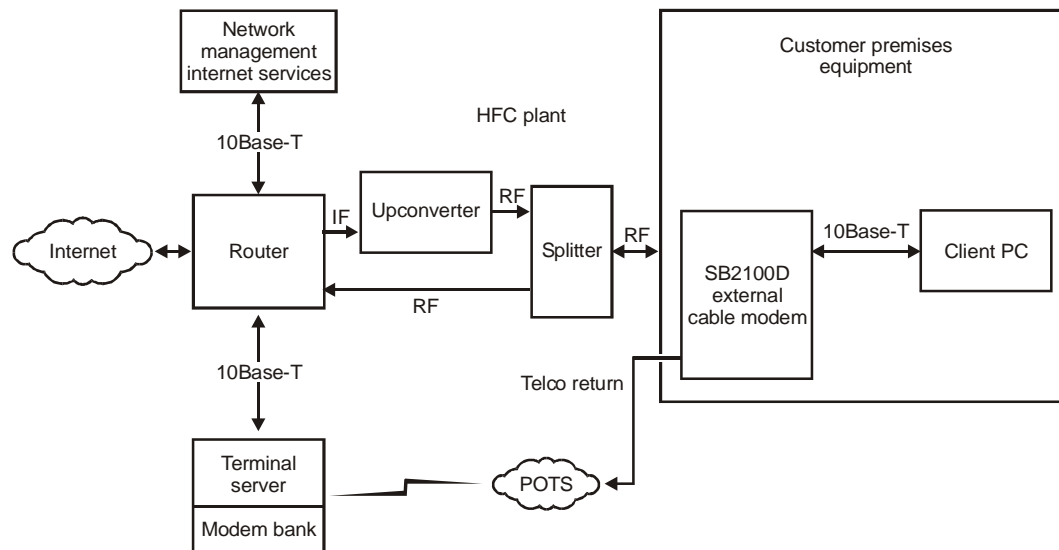

The SB2100D supports 64 and 256 QAM technology that is necessary for the DOCSIS data network. This network carries IP data in standard MPEG-2 packets. The RF downstream receives data at speeds up to 38 Mbps and RF upstream provides data transfer at rates up to 10 Mbps.

The SB2100D provides an HTML-based user interface that enables you to monitor both the cable modem and the data signals. This interface can be used to diagnose the network connections.

Front Panel

The four front-panel LEDs provide status and activity information as illustrated in Figure 2-2:

Figure 2-2
SB2100D front panel

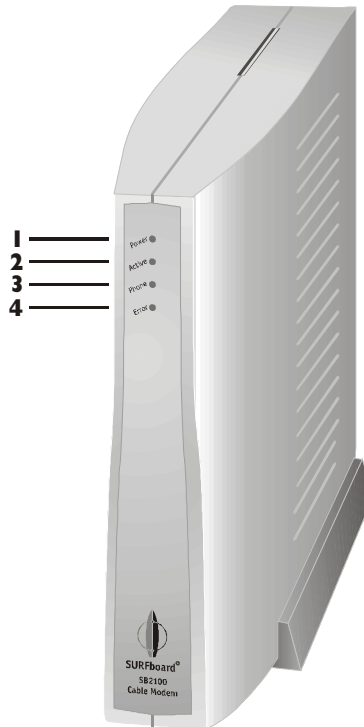

Table 2-2 describes the front-panel LEDs:

Table 2-1
Front-panel LEDs

Key	LED	Description
1	Power	Green indicates that the modem is on
2	Active	Blinking amber indicates connection status during boot up and provisioning and that data is traveling over the Ethernet connection during normal operation.
3	Phone	Amber indicates the telephone line connection is active.
4	Error	Blinking red indicates an error or start up condition and a solid red indicates rebooting.

Rear Panel

The back panel provides the connectors for all cabling, an Ethernet link status LED, and the power switch as illustrated in Figure 2-3:

Figure 2-3
Rear panel connections

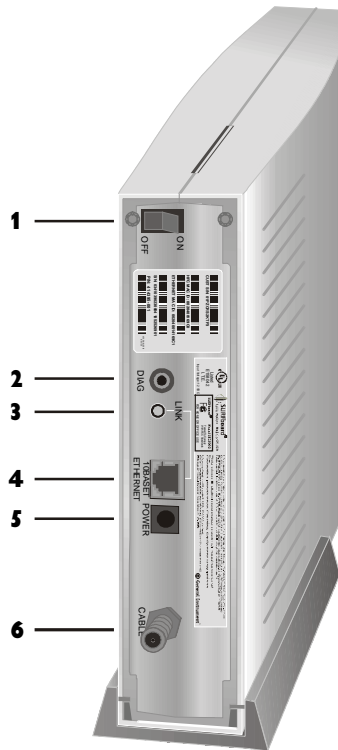

Table 2-2 describes the rear-panel connections:

Table 2-2
Rear-panel connections

Key	Item	Description
1	ON/OFF	This is the power switch.
2	DIAG	This connector is for a custom serial cable used to access the command line interface (CLI).
3	LINK	When the green LED is on, the Ethernet connection is established.
4	PHONE LINE	This port provides access to the internal telephone modem.
5	10BASE-T ETHERNET	This port provides data transfer to and from the computer.
6	POWER	This connector provides power to the SB2100D.
7	CABLE	This port provides data transfer to and from the service provider.

The DIAG port is factory disabled. To enable it, contact your General Instrument field engineer.

Section 3

Installation and Operation

This section provides instructions for cabling the SB2100D and checking its operation. To complete the installation, you must:

- Connect the cables
- Configure the customer's computer
- Power up the unit

Before You Begin

Before you begin the installation, take a few minutes to review the installation information, gather the required items, and complete the tasks listed below to make the installation as quick and easy as possible:

- 1 Verify that you received the following items with your SB2100D shipment:

Power adapter with cord	Acceptable for use with NEMA Style 5-15R ac receptacles supplying nominal 120 V
10Base-T Ethernet cable	Required to connect your computer to the SB2100D
Telephone cable	Required to connect the SB2100D to the telephone jack

- 2 Acquire the following items that are not included with the SB2100D:

75-ohm coaxial TV cable	Required to connect the SB2100D to the nearest cable outlet
5-900 MHz splitter	Required if a TV is attached to the cable outlet
Laptop	Required to access the internal Web server for diagnostics

- 3 Verify that the customer's computer has an Ethernet card installed.

Installing a Single User

To install the SB2100D:

- 1 Connect the coaxial TV cable to the SB2100D connector marked **CABLE** and the other end to the cable outlet or splitter. You may need a 5-900 MHz splitter if there is a TV connected to the cable outlet. Figure 3-1 illustrates the connections:

Figure 3-1
Cable connections

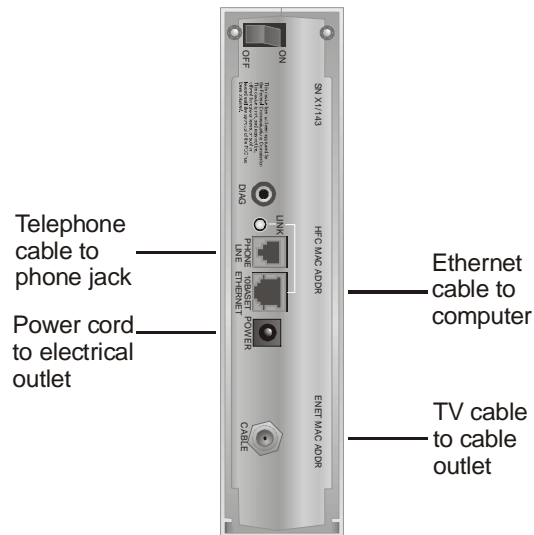

- 2 Connect the telephone cable to the SB2100D connector marked **PHONE LINE** and the other end to the phone jack.
- 3 Connect the 10Base-T Ethernet cable to the SB2100D connector marked **10BASE-T ETHERNET** and the other end to the Ethernet jack on the back of the computer.
- 4 Check that the power switch is off.
- 5 Connect the power cord to the SB2100D connector marked **POWER** and the power adapter to the electrical outlet.

Installing Multiple Users

The SB2100D can easily serve as a gateway to the Internet for up to 32 users. The users must be on the LAN and the SB2100D must be attached to the LAN and the cable system. Figure 3-2 illustrates the basic connections:

Figure 3-2
Multiple user connections

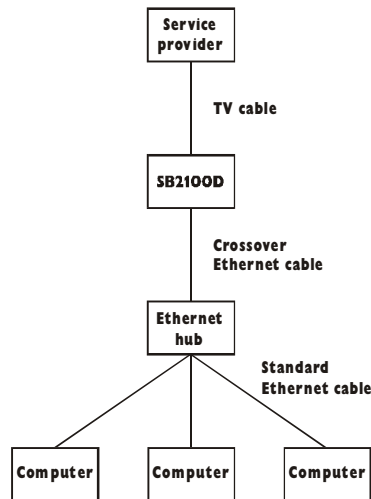

Powering Up the First Time

Powering up the SB2100D takes five to 30 minutes the first time because it must find and lock on the appropriate channels for downstream and upstream communications. To power up:

- 1 Verify that your computer is on and the SB2100D is OFF.
- 2 Turn the SB2100D ON and check that the LEDs on the front panel cycle through this sequence:
 - All four LEDs come on for several seconds.
 - The ERROR, PHONE, and the ACTIVE LEDs blink together several times and then stop.
 - The ACTIVE LED blinks at a rate of one time/second while the SB2100D scans for the downstream channel.

If the downstream channel search is longer than 30 minutes and the ERROR LED is not on, check the cable connections and then verify that the signal strength is 0 dBmV.

After the SB2100D locks on the downstream channel, the ACTIVE LED stays on for a few seconds and then starts blinking.

- The ACTIVE LED blinks at a rate of two times/second while the SB2100D scans for the upstream channel. After the SB2100D locks on the upstream channel, the ACTIVE LED stays on for a few seconds and then goes off.

If the upstream channel search is longer than 30 minutes and the ACTIVE LED is blinking slower, check the cable connections and then verify that the signal strength is 60 dBmV.

When the SB2100D is operational, the POWER LED is on and the ERROR LED is off. The ACTIVE LED is blinking during data transfer. The PHONE LED is on when the SB2100D is using the telephone modem for communication.

The SB2100D automatically loads configuration updates. It automatically reboots if the TCP/IP address and the time and date stamp are not found. The SB2100D also automatically detects whether the plant is one-way or two-way and configures itself for the appropriate mode. Refer to Section 5, "Troubleshooting" for details.

The modem should remain on. It is not necessary to turn it off when not in use.

Configuring the Computer

The SB2100D contains all necessary software. The computer must be configured for TCP/IP and have an IP address assigned. The basic instructions are provided using Windows™ 95 or Windows 98.

TCP/IP

To configure for TCP/IP:

- 1 On the Windows Desktop, click Start. The pop-up menu is displayed.
- 2 Select Settings and the Control Panel from the pop-up menus.

- 3 Double-click the Network icon on the Control Panel window. The Network window is displayed as illustrated in Figure 3-3:

Figure 3-3
Network window

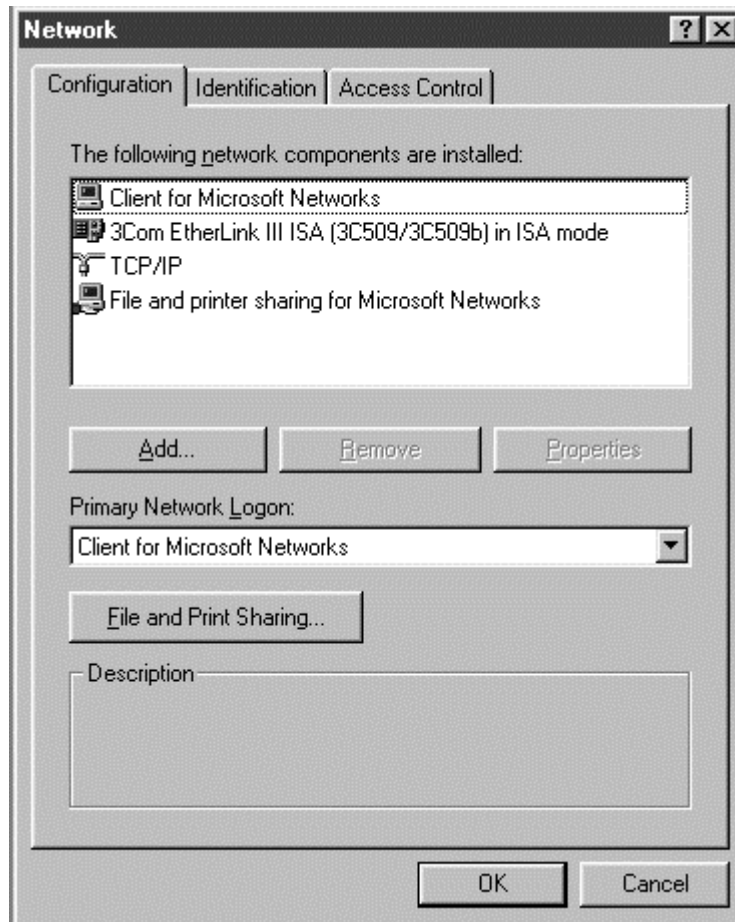

- 4 Select the Configuration tab on the Network window.
- 6 Verify that TCP/IP has been installed for the Ethernet card. If it appears in the network components installed list, proceed to step 11.

- Click Add. The Select Network Component Type window is displayed as illustrated in Figure 3-4:

Figure 3-4
Network Component Type window

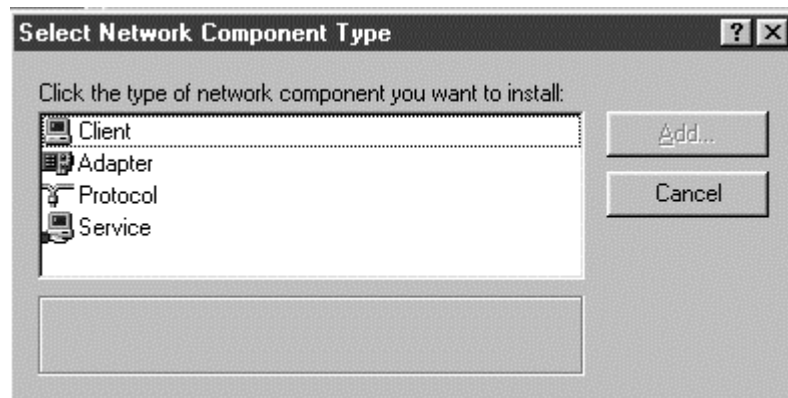

- Double-click the Protocol option. The Select Network Protocol window is displayed as illustrated in Figure 3-5:

Figure 3-5
Select Network Protocol window

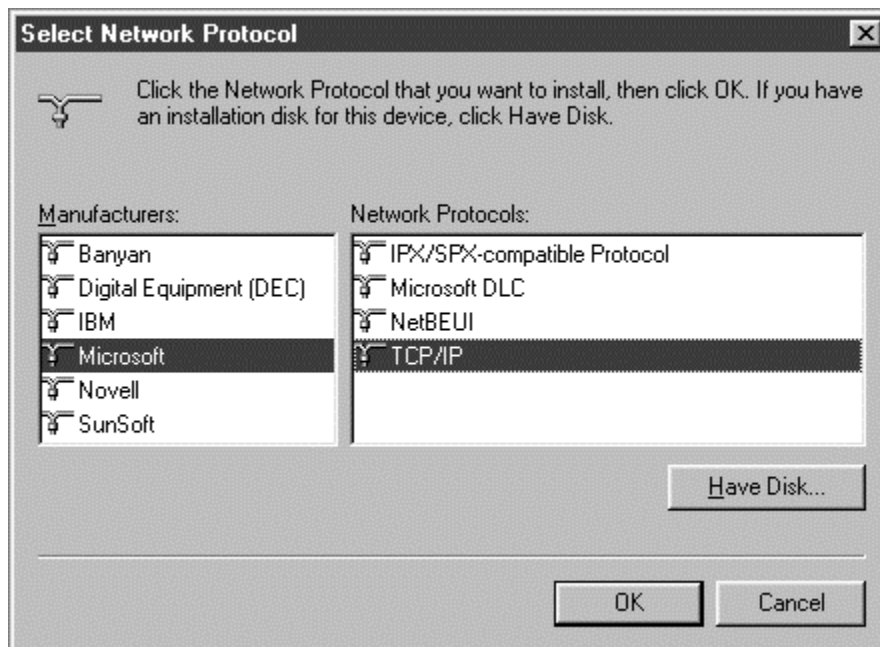

- Click Microsoft in the Manufacturers section and then click TCP/IP in the Network Protocol section.

- 10 Click OK. The Network window is displayed as illustrated in Figure 3-6:

Figure 3-6
Network window with TCP/IP selected

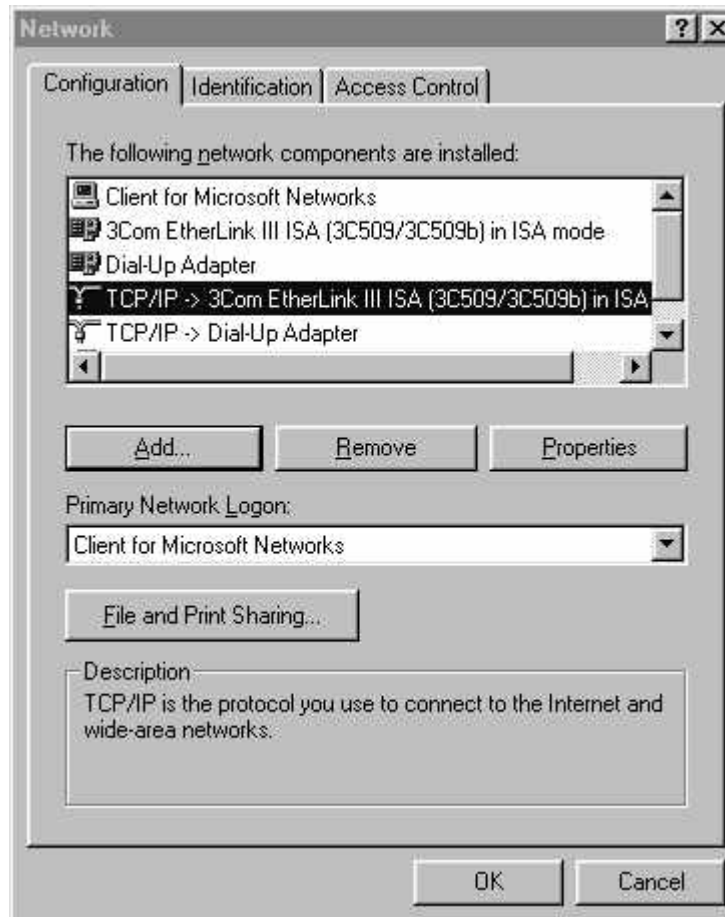

- 11 Click TCP/IP on the Network window. If you have more than one TCP/IP entry, choose the one associated with the Ethernet card connected to the SB2100D.

12 Click Properties. The TCP/IP Properties window is displayed as illustrated in Figure 3-7:

Figure 3-7
TCP/IP Properties window

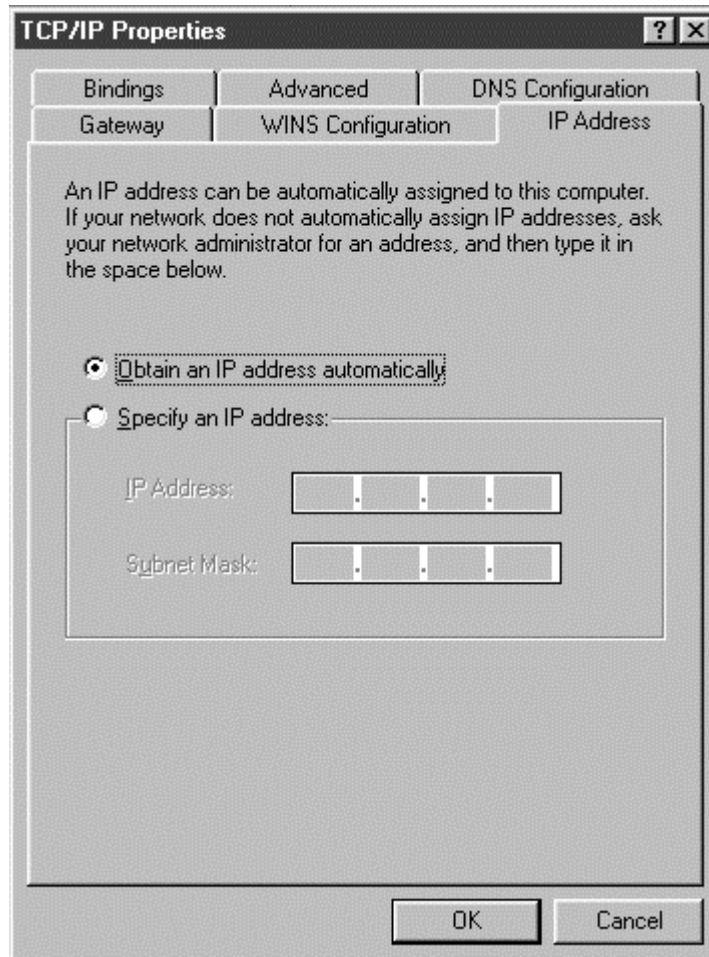

13 Select the IP Address tab.

14 Click Obtain an IP address automatically.

15 Click OK to accept the TCP/IP settings.

16 Click OK to close the Network window.

17 Click OK when a prompt to restart your computer is displayed and then click OK again.

IP Address

To check the computer IP address:

- 1 On the Windows Desktop, click Start. The pop-up menu is displayed.
- 2 Select Run and the Run dialog box is displayed as illustrated in Figure 3-8:

Figure 3-8
Run dialog box

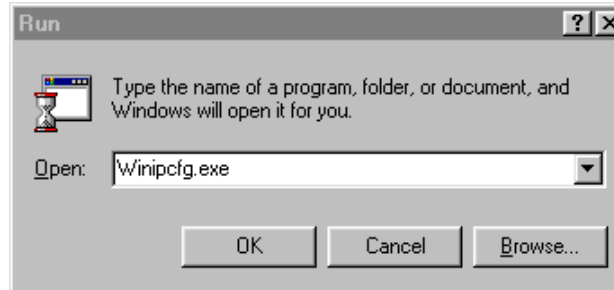

- 3 Type **Winipcfg.exe** and then click OK. The IP Configuration window is displayed as illustrated in Figure 3-9:

Figure 3-9
IP Configuration window

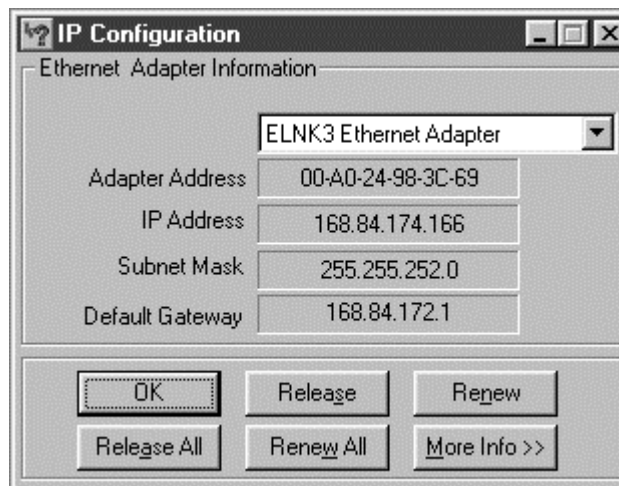

- 4 Verify that the pull-down list has the correct Ethernet adapter displayed.
- 5 Click Renew, if an IP address is not displayed.
- 6 Click OK after the system displays an IP address.

Setting the Frequency

The SB2100D has an internal HTML server that can be used to set the frequency before installing the SB2100D to save startup time. To set the frequency:

- 1 Ensure that a laptop or PC is connected to the rear-panel, 10BASE-T ETHERNET port.
- 2 Turn on the PC.
- 3 Click Start on the Windows Desktop.
- 4 Select Settings and then Control Panel from the pop-up menu.
- 5 Double-click the Network icon on the Control Panel window. The Network window is displayed as illustrated in Figure 3-6.
- 6 Select TCP/IP from the network components.
- 7 Click Properties. The TCP/IP Properties window is displayed as illustrated in Figure 3-7.
- 8 Click Specify an IP address.
- 9 Type **192.168.100.20** in the IP Address field and then type **255.255.255.0** in the Subnet Mask field.
- 10 Click OK to accept the TCP/IP settings.
- 11 Click OK to close the Network window.
- 12 Click OK when a prompt to restart your computer is displayed and then click OK again.
- 13 Open the browser.

- 14 Type <http://192.168.100.1/config.html> in the URL address line and press ENTER. The Configuration window is displayed as illustrated in Figure 3-10:

Figure 3-10
Configuration Window

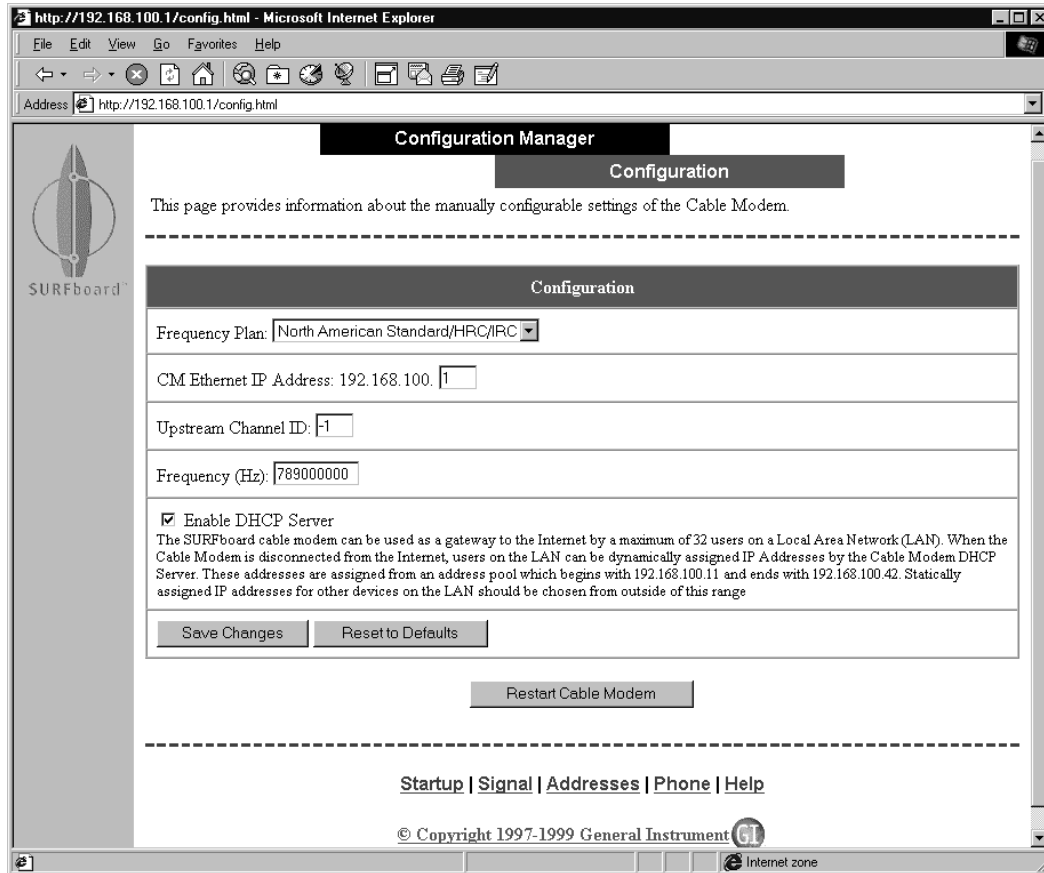

- 15 Type the desired frequency in Hertz, for example, 405 MHz = 405000000.
- 16 Click Save Changes and then Restart Cable Modem.
- 17 Click Start on the Windows Desktop.
- 18 Select Settings and then Control Panel from the pop-up menu.
- 19 Double-click the Network icon on the Control Panel window. The Network window is displayed as illustrated in Figure 3-6.
- 20 Select TCP/IP from the network components.
- 21 Click Properties. The TCP/IP Properties window is displayed as illustrated in Figure 3-7.
- 22 Click Obtain an IP address automatically.
- 12 Click OK to accept the TCP/IP settings.
- 13 Click OK to close the Network window.
- 23 Click OK when a prompt to restart your computer is displayed and then click OK again.

Configuring your System for Telco Return Mode

To use the Telco Return mode, the CMTS must be configured to transmit Telephony Channel Descriptor (TCD) messages that provide dialing and access instructions for the SB2100D. The TCD must contain at least one valid Service Provider Descriptor (SPD). The SPD must contain a factory default flag and one telephone number for the SB2100D to function properly. The SPD may also contain the following optional information:

- Two additional telephone numbers
- Service provider name
- Connection threshold
- Username
- Password
- DHCP Authenticate
- DHCP server
- Radius realm
- PPP authentication
- Demand Dial Timer

To adjust these parameters, use the HTML interface windows: Phone and Phone Setup.

If more than one telephone number is supplied, the SB2100D cycles through the telephone numbers until it establishes a PPP connection. The number of times the SB2100D attempts to make connection is set in Connection Threshold. The default value of Connection Threshold is 1 and should be increased if using more than one Phone Numbers or to allow for busy signals. A Connection Threshold of 1 only allows for one call failure for whatever reason.

If DHCP Authenticate is set to:

- | | |
|--------------|---|
| False | The DHCP Discover message from the SB2100D is sent to the broadcast address |
| True | The DHCP Discover message will be unicast to the IP address set in the DHCP Server field. |

PPP Authentication instructs the SB2100D which authentication procedure to perform. PAP or CHAP, PAP only, or CHAP only.

The Demand Dial Timer field controls the demand dial feature. If the field is non-zero, it indicates the idle time (in seconds) before disconnecting the telephone connection. If the field is zero, the telephone connection is always connected.

TFTP Configuration File

*A TFTP configuration file must be downloaded for the SB2100D to function properly. The SB2100D attempts to download the configuration file three times. If it cannot, it reboots. The configuration file *must* contain an Upstream Channel ID of zero for Telco Return mode operation. A non-zero Upstream Channel ID indicates Two-Way (RF return). If a SB2100D in Telco Return mode receives a configuration file with a non-zero Upstream Channel ID, it reboots into RF return mode.*

The DHCP server *must* include the following information in the DHCP offer message:

- The TFTP server address in the “siaddr” field
- The configuration file name in the “file” field

Cisco’s Network Registrar field names are “packet-siaddr” and “packet-filename”. These fields require the check box, Always send to DHCP clients, be enabled for each selection.

The SPD connection parameters may optionally be included in the Configuration file. If these parameters are present and different than the connection parameters used from the TCD message, the SB2100D reboots and reconnects the PPP session using the new parameters.

Upgrading the Firmware

The SB2100D automatically upgrades the firmware if a new version is found on the TFTP server or if forced to upgrade. When the SB2100D is booted, it checks the TFTP boot file for a later version, downloads the new firmware, and automatically reboots to load the new firmware. The following subsections describe the upgrade procedures using the cable network and SNMP.

Upgrading the SB2100D Over the Cable Network

To upgrade the SB2100D over the cable network:

- 1 Load the new firmware on the headend TFTP server in the same directory as the TFTP log file.
- 2 Modify the TFTP boot-file listing to reference the new file as illustrated in Figure 3-11:

Figure 3-11
Sample TFTP boot-file listing

```

=====
Configuration Information in tftp_upgrade_eng16.log
=====
Upstream Channel ID = 1
Net Access Control = 1
Class of Service Block:
Class ID = 1
Maximum DS rate = 10000000
Maximum US rate = 2000000
Vendor ID = 00 20 40
Software Upgrade File = SB2100D_1_0_0_ENG_16.hex.bin
=====
CM MIC = 95 da 90 77 4f b1 f5 42 58 79 e5 6a 56 b4 58 94
CMTS MIC = b3 13 c5 1f dd fd 35 ce e7 0d 40 1a 91 a5 3d 6e
=====
End of File

```

In our example, SB2100D_1_0_0_ENG_16.hex.bin is the updated-firmware filename. It resides in the same directory as the TFTP log file.

The TFTP boot file is a binary file. You must create the TFTP boot file using a tool provided by the CMTS vendor.

- 3 Modify the DHCP server configuration to point to the new TFTP boot file

The SB2100D firmware will be upgraded the next time the SB2100D reboots and registers on the network. SNMP can be used to force the SB2100Ds to reboot.

Upgrading the SB2100D Using SNMP

SNMP can also be used to update the SB2100D. The following lists the steps and provides the expected results. The SB2100D must be on and registered.

The following procedure is based on running the HP OpenView SNMP Network Management Package under the Solaris operating system. The MIB definitions will remain for other SNMP platforms, but the exact sequence of events to utilize the MIB and Object Ids may vary.

To upgrade the SB2100D:

- 1 Click Start on the Windows Desktop.
- 2 Select Settings and then Control Panel from the pop-up menu.
- 3 Double-click the Network icon on the Control Panel window. The Network window is displayed as illustrated in Figure 3-6.
- 4 Select TCP/IP from the network components.
- 5 Click Properties. The TCP/IP Properties window is displayed as illustrated in Figure 3-7.
- 6 Click Specify an IP address.
- 7 Type **192.168.100.20** in the IP Address field and then type **255.255.255.0** in the Subnet Mask field.
- 8 Click OK to accept the TCP/IP settings.
- 9 Click OK to close the Network window.
- 10 Click OK when a prompt to restart your computer is displayed and then click OK again.
- 11 Open a browser (Netscape or MS Internet Explorer).

- 12 Type <http://192.168.100.1/mainhelp.html>. A Configuration Manager Help window is displayed as illustrated in Figure 3-12:

Figure 3-12
Configuration Manager Help

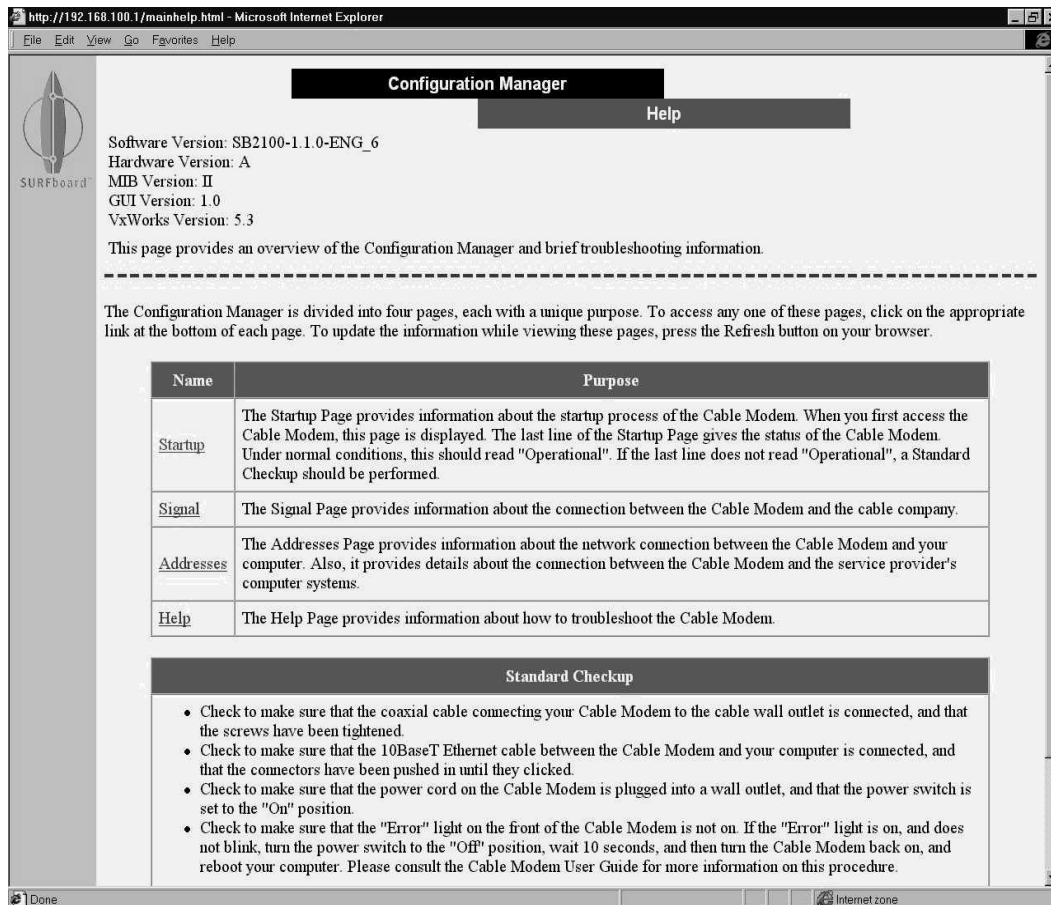

- 13 Note the software version.
- 14 Log on a management station that has HP OpenView.
- 15 Type **ovw** from xterm to start OpenView.
- 16 In the root window, choose SNMP MIB Browser from the Misc pull-down menu to start the browser.
- 17 Type **<IP address of the CM>** in the browser IP Address text box.
- 18 Type **iso.org.dod.internet**, the path name.
- 19 Click the experimental text and then Down Tree.
- 20 Click docsDevMIB text and then Down Tree.
- 21 Click docsDevMIBObjects text and then Down Tree.
- 22 Click docsDevSoftware text and then Start Query.

- 23 Click docsDevSwServer text, type **<IP address of the TFTP server where the software image resides>** in the SNMP Set Value text box, and then click Set.
- 24 Click docsDevSwFilename text, type **<software filename>** in the SNMP Set Value text box, and then click Set.
- 25 Click docsDevSwAdminStatus text, type **1**, and then click Set.

To check the results:

- Verify the SB2100D will restart itself after the SNMP file transfer is complete and docsDevSwOperStatus = completeFromMgt.
- Verify the software image has upgraded using the Configuration Manager Help window after the SB2100D reboot. To access the Help page, refer to the instructions on page 3-15.
- Verify the following log messages by typing <http://192.168.100.1/logs.html> and the Logs window is displayed:

```
Unit Update From SNMP....SUCCESS
```

```
Resetting due to SNMP docsDevResetNow
```

- Verify the docsDevSoftware MIB contains the following information:

docsdevSwServer	TFTP server address used for software upgrades.
docsdevSwFilename	Software-image file name to be loaded.
docsdevSwAdminStatus	Software upgrade options:
upgradeFromMgt (1)	Initiates a TFTP software image download
allowProvisioningUpgrade (2)	The SB2100D uses the software version information supplied by the provisioning server on the next reboot
ignoreProvisioningUpgrade (3)	The SB2100D disregards the software-image, upgrade information from the provisioning server
docsdevSwOperStatus	Download status:
inProgress (1)	TFTP download is underway
completeFromProvisioning (2)	The last software upgrade was a result of version mismatch
completeFromMgt (3) -	The last software upgrade was a result of setting docsDevSwAdminStatus to 1
failed (4)	The last attempted download failed, ordinarily due to TFTP timeout
other (5)	Other

Section 4

HTML User Interface

This section provides step-by-step instructions to use the SB2100D HTML user interface. The windows —Help, Startup, Signal, Addresses, and Logs — provide configuration and troubleshooting information such as, MAC and IP addresses, frequency, and events log.

The IP address for this user interface is 192.168.100.1. If the SB2100D is on a network, skip to step 11. To use the HTML user interface:

- 1 Connect a cable from the laptop or PC Ethernet port to the 10BASET ETHERNET port on the rear panel.
- 2 Turn on the PC and verify that the SB2100D is on.
- 3 Click Start on the Windows Desktop.
- 4 Select Settings and then Control Panel from the pop-up menu.
- 5 Double-click the Network icon on the Control Panel window. The Network window is displayed.
- 6 Select TCP/IP from the network components.
- 7 Click Properties. The TCP/IP Properties window is displayed.
- 8 Click Specify an IP address.
- 9 Type **192.168.100.20** in the IP address field and the type **255.255.255.0** in the Subnet Mask field.
- 10 Click OK and then reboot.
- 11 Open the browser.

- 12 Type <http://192.168.100.1/mainhelp.html>. A Configuration Manager Help window is displayed as illustrated in 4-1:

Figure 4-1
Configuration Manager Help window

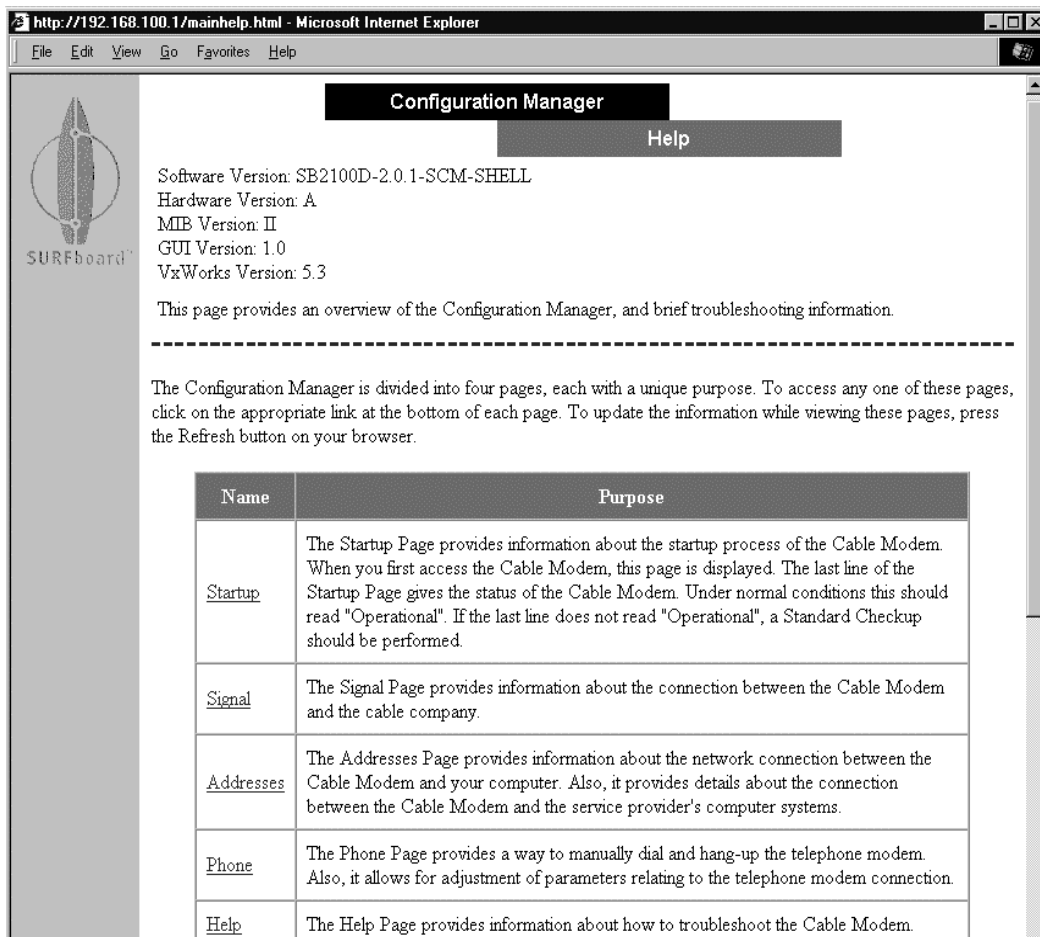

This window provides an overview of the other windows and a standard troubleshooting checklist.

- 13 Click Startup at the bottom of the HTML window and the Configuration Manager Startup window is displayed:

Figure 4-2
Configuration Manager Startup window

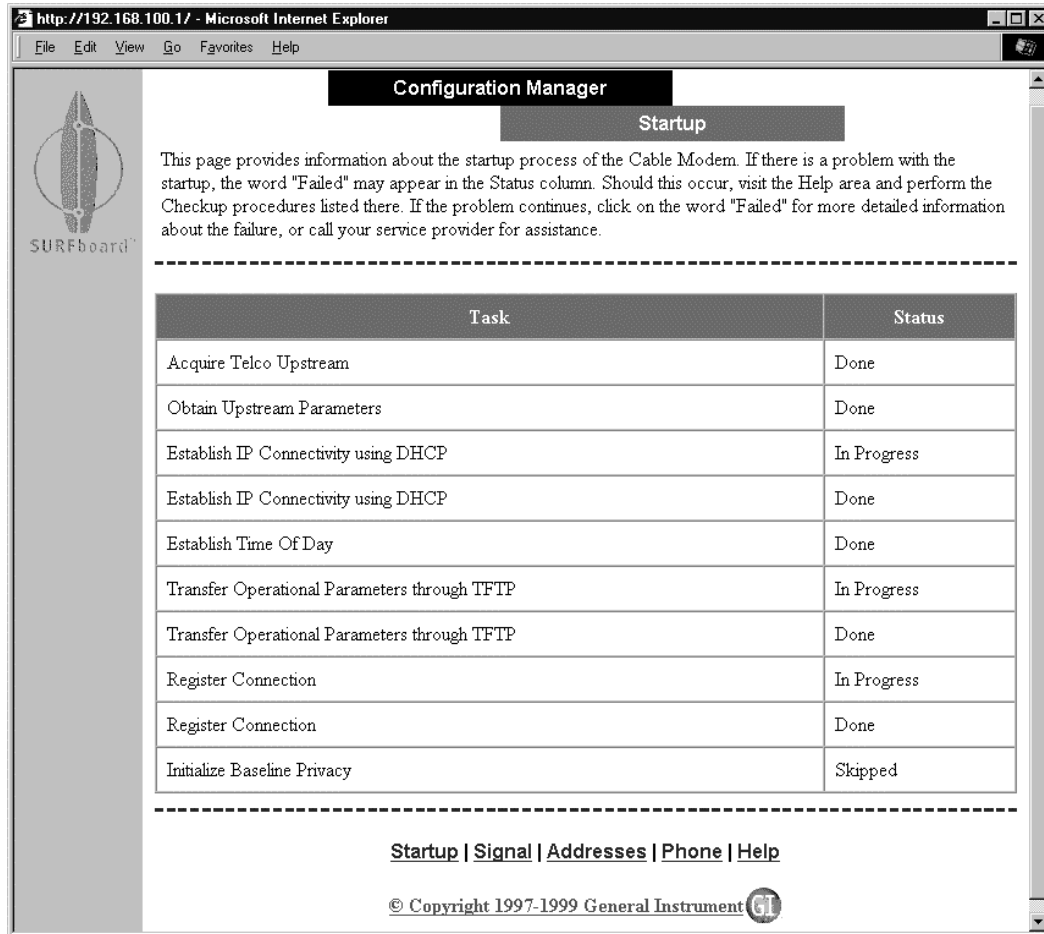

It provides a power-up status for each item on the Task list. As illustrated in Figure 4-2, the last Status entry should be Operational.

- Click Signal at the bottom of the HTML window and the Configuration Manager Signal window is displayed:

Figure 4-3
Configuration Manager Signal window

Configuration Manager

Signal

This page provides information about the current upstream and downstream signal status of your Cable Modem.

Downstream	Value
Frequency	789000000 Hz Locked
Signal to Noise Ratio	34 dB
Max bitrate	10000000 bps
QAM	64
Network Access Control Object	ON

Upstream	Value
Phone Number	4043902
Modem Status	Connected at 33600

[Startup](#) | [Signal](#) | [Addresses](#) | [Phone](#) | [Help](#)

© Copyright 1997-1999 General Instrument 

This window provides the current downstream and upstream information.

- 15 Click Address at the bottom of the HTML window and the Configuration Manager Addresses window is displayed:

Figure 4-4
Configuration Manager Addresses window

Configuration Manager

Addresses

This page provides information about the servers your Cable Modem is using, and the computers to which it is connected.

Item	Value
Serial Number	035103833100041451530000
HFC IP Address	206.19.86.138
HFC MAC Address	00:20:40:01:4B:1E
Ethernet IP Address	192.168.100.1
Ethernet MAC Address	00:20:40:01:4B:1F
DHCP Server Address	206.19.86.15
DHCP Information	Duration: 604800 s Time: 0

#	Known CPE MAC Address (Max 1)	Status
1	00:A0:C9:AB:5A:F1	Learned

[Startup](#) | [Signal](#) | [Addresses](#) | [Phone](#) | [Help](#)

© Copyright 1997-1999 General Instrument

- 16 Click Phone at the bottom of the HTML window and the Configuration Manager Phone window is displayed:

Figure 4-5
Configuration Manager Phone Window

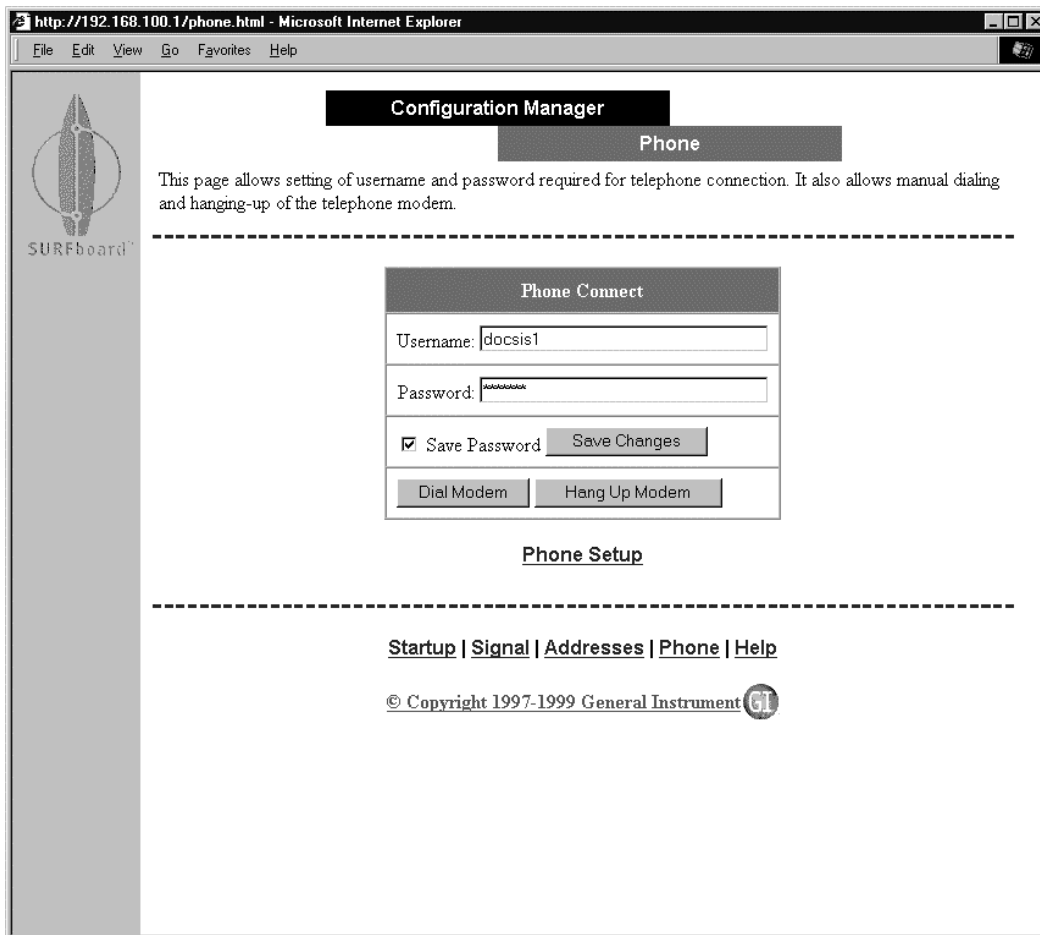

- 17 Click Phone Setup at the bottom of the Phone window and the Phone Setup window is displayed:

Figure 4-6
Configuration Manager Phone Setup window

Configuration Manager

Phone Setup

This page allows for the adjustment of parameters relating to the telephone modem. Correct values for the items on this page should be obtained from your service provider.

Phone Setup

Phone Prefix:

Phone Number:

Modem Init String:

Use DHCP Authentication
DHCP Server Address:

PPP Authentication Type:
 Automatic PAP Only CHAP Only

Radius Realm:

Downstream Channel IP Address:

Registration IP Address:

Modem Speaker Volume:
 Off Low Default Medium High

- 18 Type <http://192.168.100.1/logs.html> and the Configuration Manager Logs window is displayed:

Figure 4-7
Configuration Manager Logs Window



Time	Priority	Code	Message
990630162006	7-Information	I0.0	REG-RSP Registration Response
990630162006	7-Information	I500.0	Registration Completed
990630162006	7-Information	B518.0	Baseline Privacy is skipped
990630162008	4-Error	T514.0	Restart Telco Upstream Ok
990630162045	7-Information	D519.0	DHCP Client shutting down.
990630162049	4-Error	T513.0	Telco Upstream has been Shut Down
990630180044	7-Information	T511.0	Acquire Telco Upstream SUCCESS
990630180044	7-Information	T500.0	Acquired Upstream SUCCESS
990630180044	7-Information	D0.0	DHCP CM Net Configuration download and Time of Day
990630180046	7-	D511.0	Retrieved DHCP SUCCESS

This is a sample Events Log that is generated during startup and during operation. Refer to Appendix B, “Event Log Messages”, for the format and code definitions.

Section 5

Troubleshooting

This section provides information to assist you in quickly detecting, isolating, and resolving error conditions that might occur when using the SB2100D. If you need assistance, call TRC at 1-888-944-HELP. Please take a minute to fill out the Troubleshooting Checklist (Table 5-2) before calling TRC.

If the SB2100D was off, it may require time to scan for the upstream and downstream channels again. Table 5-1 lists fault indications, symptoms, and possible resolutions:

Table 5-1
Troubleshooting guidelines

Problem	Possible Solution
POWER LED is off	Check that the power switch is on. Powering up may take 5 to 30 minutes. Check that the power cord at the modem and the adapter at the outlet.
Cannot receive or send data	Verify that the TV is working and has a clear picture. Check the coaxial cable at the modem and outlet and hand-tighten if necessary. Verify that the telephone cable is installed properly. Check the rear-panel LINK LED. If off, check the Ethernet cable at the modem and computer. Check the IP address (follow the steps in Section 3, "Installation").
ERROR LED blinking	Reboot the SB2100D.
POWER LED blinking	Reboot the SB2100D.
PHONE and ERROR LED on	Reboot the SB2100D.
ACTIVE and ERROR LED ON	Reboot the SB2100D.

Table 5-2 is the troubleshooting checklist that provides TRC with needed information:

Table 5-2
Troubleshooting checklist

Complete description of the problem

Network layout and IP addresses

Firmware version *

CMTS

Type

Operating system version

DHCP

Operating system

Software version

Copy of the Event Log *

Copy of TFTP configuration file

Where in boot sequence does the SB2100D fail, monitor the LEDs and the console cable output if active

Does it acquire a downstream frequency lock?

Does it acquire an upstream channel?

Does it complete DHCP registration?

Does it get a successful TFTP download?

Did you provision the Ethernet MAC address in DHCP?

Did it work at one time, and if so, what has changed?

Does this issue effect other DOCSIS vendor modems?

Does this issue effect all nodes in the cable system?

Does the SB2100D work if provisioned in the headend, for example system test point or right at the node?

What application, if any, is failing and in what way?

If multi-user, is the MAX-CPE turned on in the TFTP bootfile?

* Firmware version and Event Log are accessible using SNMP Console Cable output (if active) or HTML (Help window at 192.168.100.1).

Appendix A

Specifications

Downstream

Modulation	64 or 256 QAM
Data rate	10 Mbps maximum (limited by Ethernet)
Frequency	88 through 860 MHz (30 kHz minimum step size)
Bandwidth	6 MHz
Symbol rate	
64 QAM	5.069 Msym/s maximum
256 QAM	5.361 Msym/s maximum
Operating level	-15 through +15 dBmV
Input impedance	75 ohm nominal
Total input power	< 30 dBmV

Upstream

Modulation	16 QAM or QPSK (variable symbol rates)
Transmission rate	10 Mbps maximum
Frequency	5 through 42 MHz (edge to edge)
Symbol rates	160, 320, 640, 1280, and 2560 ksym/s
Operating levels	
16 QAM	+8 through +55 dBmV
QPSK	+8 through +58 dBmV
Output impedance	75 ohm nominal
Total input power	< 35 dBmV (varies by symbol rate)

General

Data protocol	TCP/IP
Interface to PC	Ethernet 10Base-T
Power	14 Watts
Input power	+12 Vdc @ 1.25 A
Operating temperature	0 to +40°C
Storage temperature	-20 through +80°C
Operating humidity	10 through 85% RH, non-condensing

Appendix B

Event Log Messages

This appendix provides the meaning of the messages in the Events Log. This log is generated during startup and operation and contains up to 200 entries.

Event Message Format

The entries can be 80 characters and contain a timestamp, the priority level, letter and numeric code.

The format is MMDDHHMMSS P XNNN.N event message.

MMDDHHMMSS	Time stamp consisting of 10 characters. ***** is displayed until the time is retrieved from the time server.
P	Log priority level (refer to Table B-1)
X	Letter code (refer to Table B-2 and B-3)
NNN.N	Numeric code (refer to Table B-2 and B-3)
Event message	String reporting status or error (can contain specific values which apply to the event being reported)

Priority Levels

Table B-1 describes the priority level:

Table B-1
Priority level

Priority Level	Description	LOG PRIORITY LEVEL
1	Emergency	A panic condition that is broadcasted to all users.
2	Alert	A condition to be corrected immediately, such as a corrupted system database.
3	Critical	A critical condition such as hard device errors
4	Error	Error messages
5	Warning	Warning messages
6	Notice	Conditions that are not error conditions, but that may require special handling
7	Information	Information messages
8	Debug	Messages that contain information normally used to debug a program

Predefined log messages

SP-RFI_I04-980724 – Error Codes for MAC Management Messages

Code	Event Log Messages	Level	Cable Modem Actions
SYNC Timing Synchronization			
T00.0	SYNCTiming Synchronization		
T01.0	Failed to acquire QAM/QPSK symbol timing. Error stats? Retry #'s?		
T02.0	Failed to acquire FEC framing. Error stats? Retry #'s? # of bad frames?		
T02.1	Acquired FEC framing. Failed to acquire MPEG2 Sync. Retry #'s?		
T03.0	Failed to acquire MAC framing. Error stats? Retry #'s? # of bad frames?		
T04.0	Failed to Receive MAC SYNC frame within time-out period.		
T05.0	Loss of Sync. (Missed 5 in a row, after having Synced at one time)		
UCD Upstream Channel Descriptor			
U00.0	UCD Upstream Channel Descriptor		
U01.0	No UCD's Received. Time-out		
U02.0	UCD invalid or channel unusable.		
U03.0	UCD valid, BUT no SYNC received. TIMED OUT.		
U04.0	UCD, & SYNC valid, NO MAPS for THIS Channel.		
U05.0	UCD received with invalid or out of order Configuration Change Count.		
U06.0	US Channel wide parameters not set before Burst Descriptors		
MAP Upstream Bandwidth Allocation			
M00.0	MAP Upstream Bandwidth Allocation		
M01.0	A transmit opportunity was missed because the MAP arrived too late		

Code	Event Log Messages	Level	Cable Modem Actions
RNG-RSP Ranging Response			
R00.0	RNG-RSP Ranging Response		
R01.0	NO Maintenance Broadcasts for Ranging opportunities Received T2 time-out.		
R02.0	No Ranging Response received, T3 time-out		
R03.0	Ranging Request Retries exhausted.		
R04.0	Received Response to Broadcast Maintenance Request, But no Unicast Maintenance opportunities received. T4 time-out.		
R05.0	Started Unicast Maintenance Ranging no Response received. T3 time-out.		
R06.0	Unicast Maintenance Ranging attempted, No Response, Retries exhausted.		
R07.0	Unicast Ranging Received Abort Response, Re-initializing MAC.		
RNG-REQ Ranging Request			
R100.0	RNG-REQ Ranging Request		
R101.0	No Ranging Requests received from POLLED CM (CMTS generated polls)		
R102.0	Retries exhausted for polled CM (report SID). After 16 R101.0 errors.		
R103.0	Unable to Successfully Range CM (report SID) Retries Exhausted. Note: this is different from R102.0 in that it was able to try, i.e. got REQ's but failed to Range properly.		
R104.0	Failed to received Periodic RNG-REQ from modem (SID X), Timing-out SID.		
REG-REQ Registration Request			
I100.0	REG-REQ Registration Request	7 (Info)	No action taken
I101.0	Invalid MAC header.		
I102.0	Invalid SID, not in use.		
I103.0	Required TLV's out of order.		
I104.0	Required TLV's not present.		
I105.0	Down Stream Frequency format invalid in length.	4 (Error)	Won't be saved to memory
I105.1	Down Stream Frequency not in use.		
I105.2	Down Stream Frequency invalid, not a multiple of 62500Hz.	4 (Error)	CM will continue reading next bytes of Config file. Set to 0 value
I106.0	Up Stream Channel invalid, unassigned.	4 (Error)	

Code	Event Log Messages	Level	Cable Modem Actions
I106.1	Up Stream Channel Change followed with (RE-) Registration REQ.		
I107.0	Up Stream Channel overloaded.		
I108.0	Network Access configuration has invalid parameter (length).	4 (Error)	Continue reading next bytes of Config file. Set to 0 value
I109.0	Class of Service configuration is invalid.		
I110.0	Class of Service ID is not in TFTP config.	7 (Info)	No action taken
I111.0	Class of Service ID out of range.	4 (Error)	Continue reading next bytes of Config file. Log it. If Reg-Response returns OK, reboot to notify CMTS the range error
I111.1	Class of Service ID invalid length	4 (Error)	
I112.0	Max Downstream Bit rate configuration has invalid length	4 (Error)	Continue reading next bytes of Config file. Set to 0 value
I112.1	Max Downstream Bit Rate configuration is not in TFTP config.	7 (Info)	Continue reading next bytes of Config file. Set to 0 value
I113.0	Max Upstream Bit rate configuration has invalid length	4 (Error)	Continue reading next bytes of Config file. Set to 0 value
I113.1	Max Upstream Bit Rate configuration is not in TFTP config	7 (Info)	Continue reading next bytes of Config file.
I114.0	Up Stream Priority configuration invalid format.	4 (Error)	
I114.1	Up Stream Priority configuration setting out of range.	4 (Error)	Continue reading next bytes of Config file. Set to 7 value as lowest priority
I114.2	Upstream Priority configuration has invalid length	4 (Error)	Set to correct length and continue reading next bytes of Config file.
I114.3	Vendor Spec has invalid length/type of vendor ID	4 (Error)	Set to correct length and continue reading next bytes of Config file.
I114.4	Vendor Spec has invalid length	4 (Error)	Set to correct length and continue reading next bytes of Config file.
I115.0	Min Upstream Channel Bit Rate configuration setting invalid length	4 (Error)	Continue reading next bytes of Config file. Set to 0 value
I115.1	Guaranteed Min Up Stream Channel Bit Rate configuration setting exceeds Max Upstream Bit Rate.	4 (Error)	Continue reading next bytes of Config file. Set to Max
I115.2	Guaranteed Min Up Stream Channel Bit Rate configuration setting out of range		
I116.0	Max Upstream Channel Transmit Burst configuration setting invalid length	4 (Error)	Continue reading next bytes of Config file. Set to 0 value
I116.1	Max Up Stream Channel Transmit Burst configuration setting out of range	4 (Error)	Continue reading next bytes of Config file. Set to 255
I117.0	Modem Capabilities configuration setting invalid format.	7 (Info)	Continue reading next bytes of Config file. Set to 0 value
I117.1	Modem Capabilities configuration setting.	7 (Info)	No action taken

Code	Event Log Messages	Level	Cable Modem Actions
REG-RSP Registration Response			
I00.0	REG-RSP Registration Response	7 (Info)	No action taken
I01.0	Registration RSP invalid format or not recognized	4 (Error)	Ignore it and continue reading next bytes of REG-RSP msg
I02.0	Registration RSP not received.	4 (Error)	Reset the board.
I03.0	Registration RSP with bad SID.	4 (Error)	Continue reading next bytes of REG-RSP msg.
I04.0	Service not available. Reason: Other		
I04.1	Service not available. Reason: Unrecognized configuration setting		
I04.2	Service not available. Reason: Temporarily unavailable		
I04.3	Service not available. Reason: Permanent		
UCC-REQ Upstream Channel Change Request			
C00.0	UCC-REQ Upstream Channel Change Request	7 (Info)	No action taken
C01.0	Async Msg received with invalid US Channel ID length.	4 (Error)	CM will fix to correct length, continue parsing the channel ID value, and send UCC-RSP to CMTS.
C02.0	UCC-REQ received unable to send UCC-RSP, no TX opportunity.		
UCC-RSP Upstream Channel Change Response			
C100.0	UCC-RSP Upstream Channel Change Response	7 (Info)	No action taken
C101.0	UCC-RSP not received on previous channel ID.		
C102.0	UCC-RSP received with invalid channel ID.		
C103.0	UCC-RSP received with invalid channel ID on new channel.		
DHCP CM Net Configuration download and Time of Day			
D00.0	DHCP CM Net Configuration download and Time of Day	7 (Info)	No action taken
D01.0	Discover sent no Offer received, No available DHCP Server.	4 (Error)	
D02.0	Request sent, no Response.	4 (Error)	
D03.0	Requested Info not supported.	4 (Error)	
D03.1	DHCP response doesn't contain ALL the valid fields as described in the RF spec Appendix C.1	4 (Error)	
D04.0	Time of Day, none set or invalid data.		
D04.1	Time of Day Request sent no Response received	5 (Warn)	CM will time out in 10 secs and retry 2 nd time. If still fails, ignore it
D04.2	Time of Day Response received but invalid data/format.	5 (Warn)	CM will time out in 10 secs and retry 2 nd time. If still fails, ignore it

Code	Event Log Messages	Level	Cable Modem Actions
D05.0	TFTP Request sent, No Response/No Server.	1 (Alert)	<p>CM will keep retrying 3 times. If unsuccessfully, reset the board and still acquire to the same frequency.</p> <p>If still failed after 3 attempts, again, reset the board 2nd time and try to acquire to the 2nd frequency in memory.</p> <p>If still failed after 3 attempts, reset the board 3rd time and try to scan the next frequency in the frequency plan. The board will eventually reboot due to incomplete registration</p> <p>Notes: Type "clrscanflag" and reset the board if don't want to go through all the retrying process. What it does is it will acquire the current frequency over and over when 3 TFTP attempts are failed</p>
D06.0	TFTP Request Failed, configuration file NOT FOUND.	1 (Alert)	
D07.0	TFTP Failed, OUT OF ORDER packets.		
D08.0	TFTP complete, but failed Integrity Check (MIC).	1 (Alert)	Same as D05.0
D09.0	TFTP, Unable to allocate spaces, CONTINUE	4 (Error)	CM continues reading the next bytes of REG-RSP msg
D10.0	REG-RESP, Serv Not Avail Resp Len	4 (Error)	CM set to correct length and continue reading the next bytes
B00.0	Baseline Privacy	7 (Info)	No action taken
B01.0	TBD		

SB2100D Specific Log Messages

Code	Event Log Messages	Level	Cable Modem Actions
Baseline Privacy			
B500.0	Error occurred while reading MAC messages for BLP	4 (Error)	Discard the msg and wait for the next one
B502.0	Unmatched Id when received Auth Reply [ReqId] [ReclId]	2 (Alert)	Discard the msg and wait for the next one
B502.1	Unmatched Id when received Key Reply [ReqId] [ReclId]	2 (Alert)	Discard the msg and wait for the next one
B502.2	Unmatched Id when received Auth Invalid [ReqId] [ReclId]	2 (Alert)	Unsolicited ID. Continue parsing next bytes
B502.3	Unmatched Id when received TEK Invalid Msg [ReqId] [ReclId]	2 (Alert)	Unsolicited ID. Continue parsing next bytes
B503.0	Invalid Key Seq Num type [invalid type num] from Auth Reply Msg	4 (Error)	Ignore it. Continue parsing next bytes
B503.1	Invalid type [type] from Auth Reject or TEK Invalid Msg	4 (Error)	Ignore it. Continue parsing next bytes
B503.2	Invalid Auth key type [type] from Auth Reply Msg	4 (Error)	Ignore it. Continue parsing next bytes

Code	Event Log Messages	Level	Cable Modem Actions
B503.3	Invalid Error Code type [invalid type num] from Auth Reject or TEK Invalid Msg	4 (Error)	Discard the Auth Reject or TEK Invalid Msg
B503.4	Invalid Error String type from Auth Reject or Auth Invalid Msg	4 (Error)	Ignore it. Continue parsing next bytes
B503.5	Invalid Auth key type [type] from Auth Reply Msg	4 (Error)	Ignore it. Continue parsing next bytes
B504.0	Invalid type [type] from Key Reply Msg	4 (Error)	Ignore it. Continue parsing next bytes
B504.1	Invalid SID [Sid Num] from Key Reply Msg	4 (Error)	Discard the msg and call HandleTekInvalid() to issue another key request to CMTS
B504.2	Invalid HMAC Digest type [type] from Key Reply Msg	4 (Error)	Ignore it
B504.3	Invalid Msg type [type] from Key Reject or TEK Inv	4 (Error)	Ignore it. Continue parsing next bytes
B504.4	Invalid SID [sid] from Key Reject or TEK Inv	4 (Error)	Discard the msg.
B505.0	BC3220 driver supports up to [nsid] Sids and CMTS sent [nsids] Sids	5 (Warn)	Set up to nsids(4) BC3220 supports
B506.0	Unmatched Identifier when received Auth Reject Msg, ReqId = [reqid], Rec Id = [recid]	2 (Alert)	Unsolicited ID. Continue parsing next bytes
B507.0	Received BLP MAC code type [Type] from CMTS	7 (Info)	For information purpose
B507.1	Received Invalid BLP MAC code type [type] from CMTS	7 (Info)	Continue parsing next bytes
B508.0	Received BLP Internal Msg [Msg]	7 (Info)	For information purpose
B509.0	Authentication HMAC digest Failed. Invalid Packet	4 (Error)	Ignore it. CMTS send 0 HMAC Digest value.
B510.0	Driver has forwarded INVALID TEK Sid.	5 (Warn)	Discard the message
B510.1	SNMP forwarded INVALID Sid %d. Unable to enable it	5 (Warn)	Discard the message
B510.2	SNMP forwarded INVALID Sid %d or it's already disabled	5 (Warn)	Discard the message
B511.0	KEK bad state on HandleTimer()	2 (Alert)	Discard the message
B511.1	KEK bad state on HandleStartup()	2 (Alert)	Discard the message
B511.2	KEK bad state [state] on HandleAuthOk()	2 (Alert)	Discard the message
B511.3	KEK bad state on HandleAuthReject()	2 (Alert)	Discard the message
B511.4	KEK bad state on HandleAuthInvalid()	2 (Alert)	Discard the message
B511.5	KEK bad state on ForceReauth()	2 (Alert)	Discard the message
B512.0	Author Reject error code [error code]	4 (Error)	Report error code to SNMP event log
B513.0	Error writing BLP data to MAC pipe	4 (Error)	No action taken
B514.0	Driver allows [NumSid] Sids, CMTS provided [NumSid] Sids	5 (Warn)	Set to nSids in Driver
B515.0	Throw away this Sid [NumSid]	5 (Warn)	No action taken
B516.0	TEK bad state on HandleTimer()	2 (Alert)	Discard the message
B516.1	TEK bad state on HandleStartup()	2 (Alert)	Discard the message
B516.2	TEK bad state on HandleStop()	2 (Alert)	Discard the message

Code	Event Log Messages	Level	Cable Modem Actions
B516.3	TEK bad state on HandleAuthPending()	2 (Alert)	Discard the message
B516.4	TEK bad state on HandleAuthComplete()	2 (Alert)	Discard the message
B516.5	TEK bad state on HandleTekInvalid()	2 (Alert)	Discard the message
B516.6	TEK bad state %d on Key Reply()	2 (Alert)	Discard the message
B516.7	TEK bad state on HandleKeyReject()	2 (Alert)	Discard the message
B517.0	Received Auth Invalid with error code [ErrorCode]	4 (Error)	Report error code to SNMP event log
B517.1	Received SNMP Rekey . Unauthorized CM	4 (Error)	Report error code to SNMP event log
B517.2	Received Key Reject with error code [ErrorCode]	4 (Error)	Report error code to SNMP event log
B517.3	Received TEK Invalid Msg with error code [ErrorCode]	4 (Error)	Report error code to SNMP event log
B518.0	Baseline privacy is skipped	7 (Info)	For information purpose
B519.0	Missing required attributes from Key Reply msg [number]	2 (Alert)	Silently discarded and send another Key Request to CMTS
B520.0	Missing required attributes from Auth Reply msg [number]	2 (Alert)	MUST silently discarded according to PICS. However, current image, CM always received up to 3 attributes vs 4 from CMTS, we have to take it anyway. Need to fix it later to silently discard.
B521.0	BPKM message packet len [packet len value] > length field [length field value]	7 (Info)	Ignore it. Continue parsing the msg
B521.1	BPKM message packet len [packet len value] < length field [length field value]	7 (Info)	Discard the message
B522.0	Ignore invalid error code [error code].	7 (Info)	Discard the message
B523.0	Error extracting Author Reject Msg	4 (Error)	Discard the message
B523.1	Error extracting Key Reject Msg	4 (Error)	Discard the message
B523.2	Error extracting Author Invalid Msg	4 (Error)	Discard the message
B523.3	Error extracting TEK Invalid Msg	4 (Error)	Discard the message
B524.0	Unmatched Identifier when received Key reject Msg [ReqId] [ReclId]	2 (Alert)	Unsolicited ID. Continue parsing the next bytes
B530.0	Unable to allocate private key	1 (Emerg)	No action taken. For future development will reset the CM
B531.0	Unable to create decryption algorithm object	1 (Emerg)	No action taken. For future development will reset the CM
B532.0	Unable to set decryption algorithm object	1 (Emerg)	No action taken. For future development will reset the CM
B533.0	Unable to initialize RSA decryption	1 (Emerg)	No action taken. For future development will reset the CM
B534.0	Unable to perform RSA decryption	1 (Emerg)	No action taken. For future development will reset the CM
B535.0	Unable to finalize RSA decryption	1 (Emerg)	No action taken. For future development will reset the CM
B550.0	SNMP REKEY TEK, Out of buffer to store Disable Sid [SID]	5 (Warn)	Will go away (Waiting for ECN to inform that we don't support the enable/disable SID)

Code	Event Log Messages	Level	Cable Modem Actions
B551.0	Invalid Sid From Key Reply, Issue Another Key Req	1 (Emerg)	Discard the message and issue another Key request
B555.0	First DRIVER_TEK_INVALID Msg	7 (Info)	Information purpose to indicate that CM just receives a first TEK Invalid Message from the driver due to CRC failed.
B555.1	Just received another TEK_INVALID Msg	7 (Info)	Information purpose to indicate that CM received another TEK Invalid message from the driver due to CRC failed
B556.0	BLP - Authorization Wait Timeout out of range	4 (Error)	Log it
B556.1	BLP - Reauthorization Wait Timeout out of range	4 (Error)	Log it
B556.2	BLP - Operational Wait Timeout out of range	4 (Error)	Log it
B556.3	BLP - Rekey Wait Timeout out of range	4 (Error)	Log it
B556.4	BLP - TEK Grace Timeout out of range	4 (Error)	Log it
B556.5	BLP - Authorization Reject Wait Timeout out of range	4 (Error)	Log it
B556.6	BLP - Authorization Grace Timeout out of range	4 (Error)	Log it
DHCP / TFTP			
D500.0	Error in initializing DHCP Client	4 (Error)	
D501.0	TFTP - Unable to allocate spaces for Modem Capabilities data.	4 (Error)	Set value to 0. Possibly reset the board
D501.1	TFTP, Unable to allocate space for software upgrade filename, CONTINUE	4 (Error)	Set to NULL.
D501.2	TFTP, Unable to allocate spaces for Class of Service, CONTINUE	4 (Error)	Set to NULL.
D501.3	TFTP, Unable to allocate spaces for SNMP Access Ctrl Obj, CONTINUE	4 (Error)	Set to NULL.
D501.4	TFTP, Unable to allocate space for SNMP Access Ctrl, CONTINUE	4 (Error)	Set to NULL.
D501.5	TFTP, Unable to allocate spaces for SNMP MIB Obj, CONTINUE	4 (Error)	Set to NULL.
D501.6	TFTP, Unable to allocate spaces for whole buffer	4 (Error)	Set to NULL. The board will reset
D501.7	TFTP, Unable to allocate spaces for Vendor Spec Data, CONTINUE	4 (Error)	Set to NULL
D501.8	TFTP, Unable to allocate spaces for vendor spec	4 (Error)	Set to NULL
D501.9	TFTP, Unable to allocate spaces for SNMP Write Access Control Data, CONTINUE	4 (Error)	Set to NULL
D502.0	TFTP, Invalid CM MIC Len, CONTINUE	4 (Error)	Continue parsing the next bytes
D502.1	TFTP, Invalid CMTS MIC Len, CONTINUE	4 (Error)	Continue parsing the next bytes
D502.2	TFTP, Invalid Vendor ID Len, CONTINUE	4 (Error)	Continue parsing the next bytes
D502.3	TFTP, Invalid SNMP MIB Obj Len, CONTINUE	4 (Error)	Continue parsing the next bytes
D502.4	TFTP, Modem IP Addr Len, CONTINUE	4 (Error)	Continue parsing the next bytes

Code	Event Log Messages	Level	Cable Modem Actions
D502.5	TFTP, Serv Not Avail Resp Len, CONTINUE	4 (Error)	Continue parsing the next bytes
D502.6	TFTP, CPE Ether MAC Addr Len, CONTINUE	4 (Error)	Continue parsing the next bytes
D502.7	TFTP, SNMP IP Addr Len, CONTINUE	4 (Error)	Continue parsing the next bytes
D502.8	Invalid Class Of Service Privacy Enable Length	4 (Error)	Continue parsing the next bytes
D503.0	TFTP, Max CPEs exceed its limit of 32 allowed by CM. Set to 32 only	4 (Error)	Set to 32
D503.1	TFTP, Invalid type, CONTINUE	4(Error)	Ignore that type
D507.0	Retrieved Time SUCCESS	7 (Info)	No action taken
D507.1	Retrieved Time FAILED	7 (Info)	No action taken
D508.0	Unable to retrieve Time from Time Server. Continue.	4 (Error)	CM will retry 2 nd time. If still fails, ignore it.
D509.0	Retrieved TFTP ConfigSUCCESS	7 (Info)	
D510.0	Unable to create Timer client socket	5 (Warn)	CM will retry 2 nd time. If still fails, ignore it.
D511.0	Retrieved DHCPSUCCESS	7 (Info)	
D512.0	Unable to send Timer Request	5 (Warn)	CM will retry 2 nd time. If still fails, ignore it.
D514.0	Unable to write config params to NVRAM.	1 (Emerg)	Reports flash corruption to event log.
D514.1	Unable to write logs to NVRAM.	1 (Emerg)	Reports flash corruption to event log.
D515.0	Unable to retrieve config params from NVRAM	3 (Critical)	Set to defaults
D516.0	Unable to write DHCP_LEASE_RENEWAL_FAILED to pipe	1 (Emerg)	Continue
D517.0	DHCP Lease Renewal	7 (Info)	
D518.0	Unable to write DHCP_LEASE_RENEWAL_ABOUT_TO_FAIL to pipe	1 (Emerg)	Continue
D519.0	DHCP Client shutting down	7 (Info)	Continue
D520.0	DHCP Client unable to bind HFC interface	1 (Emerg)	Retry 2 more times
D521.0	DHCP Lease Renewal Failure	5 (Warn)	Renew Lease function fails
D522.0	DHCP Lease Expired	1 (Emerg)	logged when event occurs
D523.0	DHCP Rebinding Timer Event	5 (Warn)	logged if the 87% point is reached in the lease
D530.0	DHCP - Invalid IP Address	4 (Error)	logged if the Address is 0 or FFFFFFFF return NULL pointer to SC
D530.1	DHCP - Invalid Subnet Mask	4 (Error)	logged if the Address is 0 or FFFFFFFF return NULL pointer to SC
D530.2	DHCP - Invalid TFTP Server IP Address	4 (Error)	logged if the Address is 0 or FFFFFFFF return NULL pointer to SC
D530.3	DHCP - Invalid TFTP Boot File	4 (Error)	logged if the Boot File has a strlen of 0 return NULL pointer to SC

Code	Event Log Messages	Level	Cable Modem Actions
D530.4	DHCP - Invalid Security IP Address	4 (Error)	logged if the Address is 0 or FFFFFFFF return NULL pointer to SC
D530.5	DHCP - Invalid Time Server IP Address	4 (Error)	logged if the Address is 0 or FFFFFFFF return NULL pointer to SC
D530.6	DHCP - Invalid Time Offset	4 (Error)	logged if timeoffset = 0 return NULL pointer to SC
D531.0	Class of Service is not in TFTP Config	7 (Info)	No action taken
D532.0	Missing End Data Marker, rejecting TFTP Config file.	4 (Error)	Fail TFTP. Retry twice. If still failed, reboot the board and start scanning next frequency in the plan
D533.0	Net Access Ctrl Data out of range	4 (Error)	Keep reading the next bytes of TFTP config. If Reg-Response returns OK, reboot the CM to notify the CMTS range error
D534.0	Missing Net Access Ctrl Object, rejecting TFTP Config file.	4 (Error)	Fail TFTP. Retry twice. If still failed, reboot the board and start scanning next frequency in the plan
D536.0	Invalid filename [filename]	4 (Error)	Can't retrieve the config file, retry couple times.
D537.0	Class-of-Service Privacy Enable out of range	4 (Error)	Log it and continue reading next bytes of Config file.
D538.0	TFTP - Invalid COS encoding type, CONTINUE	4 (Error)	Log it and continue reading next bytes of Config file.
D539.0	CM reset due to config value out of range	1 (Emerg)	Save all event logs to flash before resetting
Filtering			
F501.0	Bridge Hook. Init failed to get Ethernet Interface Pointer	1 (Emerg)	The CM would not return a pointer to Ethernet interface. Contact your vendor.
F501.1	BridgeHook. Init failed to get HFC Interface Pointer.	1 (Emerg)	The CM would not return a pointer to Cable interface. Contact your vendor.
F501.2	BridgeHook. Init failed to get Ethernet MAC address.	1 (Emerg)	The CM would not return the Ethernet MAC address. \ Contact your vendor.
F501.3	BridgeHook. Init failed to get HFC MAC address.	1 (Emerg)	The CM would not return the HFC MAC address. Contact your vendor.
F501.4	BridgeHook. Init failed to get Ethernet IP Address.	1 (Emerg)	The CM would not return the Ethernet IP address. Contact your vendor.
F502.1	Bridge Forwarding Enabled.	7 (Info)	Bridge Forwarding has been enabled. No other action.
F502.2	Bridge Forwarding Disabled.	7 (Info)	Bridge Forwarding has been disabled. No other action.
F502.3	Bridge Learning Enabled	7 (Info)	Bridge Learning has been enabled. No other action.
F502.4	Bridge Learning Disabled	7 (Info)	Bridge Learning has been disabled. No other action.
F502.5	Bridge MCNS BPDU Forwarding Enabled	7 (Info)	DOCSIS BPDU forwarding has been enabled. No other action.

Code	Event Log Messages	Level	Cable Modem Actions
F502.6	Bridge MCNS BPDU Forwarding Disabled	7 (Info)	DOCSIS BPDU forwarding has been disabled. No other action.
F504.1	Bridge Ethernet Hook. Failed to learn CPE MAC Address	7 (Info)	Bridge failed to learn a CPE MAC address for it's filtering table. Table is either full or corrupted. No other action taken.
F504.2	Bridge Ethernet Hook. Failed to learn Multicast Filter.	4 (Error)	Bridge failed to learn Multicast filter. Table is either full or corrupted. No other action taken by CM.
F506.0	Bridge Multicast Aging. Failed to start WatchDog Timer.	5 (Warn)	Bridge couldn't start timer for aging multicast filters. Error at system level. No other action taken.
F506.1	Bridge Multicast Aging. Failed to get mbuf to Send Igmp Request.	5 (Warn)	Bridge failed to get an mbuf to send an Igmp request for aging multicast filters. CM continues through aging loop.
F506.2	Bridge Multicast Aging. Failed to set WD timer to schedule Deletes	5 (Warn)	Could not set second watchdog timer for aging Multicast filters. CM continues through aging loop.
F507.0	MAC Filters. Constructor can't allocate memory for hash table.	1 (Emerg)	Bridge could not allocate memory for the MAC filter hash table. Startup will receive error from Bridge Init. Bridge will not be started. CM will not be able to forward traffic. Contact your vendor.
F507.1	MAC Filters Constructor. Can't allocate memory for entries array.	1 (Emerg)	Bridge could not allocate memory to hold entries for MAC filter hash table. Startup will receive error from bridge Init. Bridge will not be started. CM will not be able to forward traffic. Contact your vendor.
F507.2	MAC Filters. Set Max Entries setting max to 32. Requested max too large	5 (Warn)	Config file tried to set the MAX CPE's value to > 32. The SB2100D only supports a max of 32. Set max to 32 and write this message to log.
F507.3	MAC Filters. Set Max Entries. Can't get memory for address entries	1 (Emerg)	Bridge could not allocate memory to hold MAX CPE # of entries in MAC address hash table. Startup will receive an error. Bridge will not be started. CM will not be able to forward traffic. Contact your vendor.
F507.4	MAC Filters. Can't set Max Entries. Already have entries in the table	4 (Error)	An attempt was made to set MAX CPE's after the MAC filter table already had entries. Max not changed. No other action taken.
F507.5	MAC Filters. Add MAC Address can't add entry. Table is full.	4 (Error)	An attempt was made to add either a MAC filter or a Multicast filter to a hash table that is full. Entry not added. No other action taken.
F507.6	MAC Filters. Add MAC Address can't add entry. Table is corrupted.	4 (Error)	An attempt was made to add either a MAC filter or a Multicast filter to a hash table that is corrupted. Entry not added. Contact your vendor.
F507.7	MAC Filters. Delete MAC Address can't delete entry. Entry not found	4 (Error)	An attempt was made to delete a MAC filter or Multicast filter that did not exist. Nothing deleted.
F508.0	LLC Filters. Failed to add filter. Table full.	4 (Error)	SNMP tried to add an LLC filter and the table is full. Filter not added. Error returned to SNMP.
F508.1	LLC Filters. Failed to add filter. Filter already exists.	4 (Error)	SNMP tried to add an LLC filter that already exists. Filter not added. Error returned to SNMP.
F508.2	LLC Filters. Failed to add filter. Invalid Protocol Type.	4 (Error)	SNMP tried to add an LLC filter with an invalid protocol type. Filter not added. Error returned to SNMP.

Code	Event Log Messages	Level	Cable Modem Actions
F508.3	LLC Filters. Failed to delete filter. Filter not found.	4 (Error)	SNMP tried to delete an LLC filter that does not exist. Nothing deleted. Error returned to SNMP.
F508.4	LLC Filters. Failed to delete filter. Invalid Protocol Type	4 (Error)	SNMP tried to delete a filter with an invalid protocol type. Nothing deleted. Error returned to SNMP.
F508.5	LLC Filters. Failed to return filter matches. Filter not found.	4 (Error)	SNMP tried to read an LLC filter that doesn't exist in the table. Error returned to SNMP.
F508.6	LLC Arp Storm Filtering. Failed to Enable Filter. Already Enabled.	4 (Error)	An attempt was made to enable Arp storm filtering when it was already enabled. No action taken.
F508.7	LLC Arp Storm Filtering. Failed to start WatchDog Timer	4 (Error)	CM was unable to start timer for clearing ARP counters for ARP Storm Filters. Contact your vendor.
F509.0	IP Filter Set Default Action failed. Invalid action.	4 (Error)	SNMP tried to set docsDevFilterIpDefault to an invalid value. Default is not changed. Error returned to SNMP.
F509.1	IP Filters. Failed to add IP Filter. Invalid direction.	4 (Error)	SNMP tried to add an IP filter with an invalid value for direction. Filter is not added to filter table. Error returned to SNMP.
F509.2	IP Filters. Failed to add IP Filter. Index already exists.	4 (Error)	SNMP tried to add an IP filter with an index of a filter that already exists. Filter is not added to filter table. Error returned to SNMP.
F509.3	IP Filters. Failed to add IP Filter. Inbound filter table full.	4 (Error)	SNMP tried to add an inbound filter and the inbound filter table is full. Filter is not added to filter table. Error returned to SNMP.
F509.4	IP Filters. Failed to add IP Filter. Cannot allocate memory for entry.	1 (Emerg)	SNMP tried to add an inbound IP filter and bridge could not allocate memory to store the filter. Filter not stored. Error returned to SNMP. Contact your vendor.
F509.5	IP Filters. Failed to add IP Filter. Outbound filter table full.	4 (Error)	SNMP tried to add an outbound filter and the outbound filter table is full. Filter is not added to filter table. Error returned to SNMP.
F509.6	IP Filters. Failed to add IP Filter. Cannot allocate memory for entry.	1 (Emerg)	SNMP tried to add an outbound IP filter and bridge could not allocate memory to store the filter. Filter not stored. Error returned to SNMP. Contact your vendor.
F509.7	IP Filters. Failed to delete IP Filter. Index does not exist.	4 (Error)	SNMP tried to delete an IP filter that doesn't exist. Error returned to SNMP.
F509.8	IP Filters. Failed to return IP filter match count. Filter not found.	4 (Error)	SNMP asked to read a filter that doesn't exist. Error returned to SNMP.
F510.0	Bridge Api. Pipe creation for filter add and delete routines failed.	1 (Emerg)	The CM experienced a problem using a pipe. This is serious. Contact your vendor.
F510.1	Bridge Api. Semaphore creation for filter add/delete routines failed	1 (Emerg)	The CM experienced a problem using a semaphore. This is serious. Contact your vendor.
F510.2	Bridge Api. Failed to Add CPE filter. Semaphore take failed	2 (Alert)	The CM experienced a problem using a semaphore. This is serious. Contact your vendor.

Code	Event Log Messages	Level	Cable Modem Actions
F510.3	Bridge Api. Failed to Add CPE. Failed to open filter pipe	2 (Alert)	The CM experienced a problem using a pipe. This is serious. Contact your vendor.
F510.4	Bridge Api. Add CPE failed to retrieve add status from pipe	2 (Alert)	The CM experienced a problem using a pipe. This is serious. Contact your vendor.
F510.5	Bridge Api. Failed to Delete CPE filter. Semaphore take failed.	2 (Alert)	The CM experienced a problem using a semaphore. This is serious. Contact your vendor.
F510.6	Bridge Api. Delete CPE failed. Failed to open filter pipe.	2 (Alert)	The CM experienced a problem using a pipe. This is serious. Contact your vendor.
F510.7	Bridge Api. Delete CPE failed to retrieve add status from pipe.	2 (Alert)	The CM experienced a problem using a pipe. This is serious. Contact your vendor.
F510.8	Bridge Api. Failed Get CPE List. Semaphore take failed.	2 (Alert)	The CM experienced a problem using a semaphore. This is serious. Contact your vendor.
F510.9	Bridge Api. Failed Get CPE List. Failed to open filter pipe.	2 (Alert)	The CM experienced a problem using a pipe. This is serious. Contact your vendor.
F510.10	Bridge Api. Get CPE List failed to retrieve return value from pipe	2 (Alert)	The CM experienced a problem using a pipe. This is serious. Contact your vendor.
F510.11	Bridge Api. Failed to Add LLC filter. Semaphore take failed.	2 (Alert)	The CM experienced a problem using a semaphore. This is serious. Contact your vendor.
F510.12	Bridge Api. Add LLC Filter failed. Failed to open filter pipe.	2 (Alert)	The CM experienced a problem using a pipe. This is serious. Contact your vendor.
F510.13	Bridge Api. Add LLC Filter failed to retrieve add status from pipe	2 (Alert)	The CM experienced a problem using a pipe. This is serious. Contact your vendor.
F510.15	Bridge Api. Failed to Delete LLC filter. Semaphore take failed.”	2 (Alert)	The CM experienced a problem using a semaphore. This is serious. Contact your vendor.
F510.16	Bridge Api. Delete LLC Filter failed. Failed to open filter pipe	2 (Alert)	The CM experienced a problem using a pipe. This is serious. Contact your vendor.
F510.17	Bridge Api. Delete LLC Filter failed to retrieve add status from pipe	2 (Alert)	The CM experienced a problem using a pipe. This is serious. Contact your vendor.
F510.18	Bridge Api. Failed to Add IP filter. Semaphore take failed.”,	2 (Alert)	The CM experienced a problem using a semaphore. This is serious. Contact your vendor.
F510.19	Bridge Api. Failed to Add IP Filter. Failed to open filter pipe.	2 (Alert)	The CM experienced a problem using a pipe. This is serious. Contact your vendor.
F510.20	Bridge Api. Add IP Filter failed to retrieve add status from pipe.	2 (Alert)	The CM experienced a problem using a pipe. This is serious. Contact your vendor.
F510.21	Bridge Api. Failed to Delete IP filter. Semaphore take failed.	2 (Alert)	The CM experienced a problem using a semaphore. This is serious. Contact your vendor.
F510.22	Bridge Api. Failed to Delete IP Filter. Failed to open filter pipe.	2 (Alert)	The CM experienced a problem using a pipe. This is serious. Contact your vendor.
F510.23	Bridge Api. Delete IP Filter failed to retrieve add status from pipe.”,	2 (Alert)	The CM experienced a problem using a pipe. This is serious. Contact your vendor.
F510.25	Bridge.Api. Failed to Set IpSpoofEnroll. Semaphore take failed.	2 (Alert)	The CM experienced a problem using a semaphore. This is serious. Contact your vendor.
F510.26	Bridge Api. Failed to set IpSpoofEnroll. Failed to open filter pipe.	2 (Alert)	The CM experienced a problem using a pipe. This is serious. Contact your vendor.

Code	Event Log Messages	Level	Cable Modem Actions
F510.27	Bridge Api. Set IP Spoof Enroll failed to retrieve set status from pipe.	2 (Alert)	The CM experienced a problem using a pipe. This is serious. Contact your vendor.
F510.28	Bridge Api. Failed to Set IpSpoofMax. Semaphore take failed.	2 (Alert)	The CM experienced a problem using a semaphore. This is serious. Contact your vendor.
F510.29	Bridge Api. Failed to set IpSpoofMax. Failed to open filter pipe.	2 (Alert)	The CM experienced a problem using a pipe. This is serious. Contact your vendor.
F510.30	Bridge Api. Set IP Spoof Max failed to retrieve set status from pipe.	2 (Alert)	The CM experienced a problem using a pipe. This is serious. Contact your vendor.
F510.31	Bridge Api. Failed to Add IP Spoof Entry. Semaphore take failed.	2 (Alert)	The CM experienced a problem using a semaphore. This is serious. Contact your vendor.
F510.32	Bridge Api. Failed to Add IP Spoof Entry. Failed to open filter pipe.	2 (Alert)	The CM experienced a problem using a pipe. This is serious. Contact your vendor.
F510.33	Bridge Api. Add IP Spoof Entry failed to retrieve add status from pipe.	2 (Alert)	The CM experienced a problem using a pipe. This is serious. Contact your vendor.
F510.34	Bridge Api. Failed to Del IP Spoof Entry. Semaphore take failed.	2 (Alert)	The CM experienced a problem using a semaphore. This is serious. Contact your vendor.
F510.35	Bridge Api. Failed to Delete IP Spoof Entry. Failed open filter pipe.	2 (Alert)	The CM experienced a problem using a pipe. This is serious. Contact your vendor
F510.36	Bridge Api. Delete IP Spoof Entry. Failed to retrieve del status from pipe.	2 (Alert)	The CM experienced a problem using a pipe. This is serious. Contact your vendor
F510.37	Bridge Api. Failed to Get IP Spoof Entries. Semaphore take failed.	2 (Alert)	The CM experienced a problem using a semaphore. This is serious. Contact your vendor.
F510.38	Bridge Api. Failed to Get IP Spoof Entries. Failed open filter pipe.	2 (Alert)	The CM experienced a problem using a pipe. This is serious. Contact your vendor
F510.39	Bridge Api. Get IP Spoof Entries. Failed to retrieve get status from pipe.	2 (Alert)	The CM experienced a problem using a pipe. This is serious. Contact your vendor
F510.40	2 F510.40 Bridge Api. Failed to Set IP Default Action. Semaphore take failed	2 (Alert)	SNMP tried to change the value of docsDevFilterIPDefault. Action failed because system was not able to get necessary semaphore. This is serious. Contact your vendor
F510.41	2 F510.41 Bridge Api. Failed Set IP Default Action. Failed to open filter pipe	2 (Alert)	SNMP tried to change the value of docsDevFilterIPDefault. Action failed because system was not able open a necessary pipe. This is serious. Contact your vendor
F510.42	2 F510.42 Bridge Api. Set IP Default Action failed to retrieve pipe status	2 (Alert)	SNMP tried to change the value of docsDevFilterIPDefault. Action failed because system was not able write to a necessary pipe. This is serious. Contact your vendor
F511.1	Bridge Api. Failed to Add LLC filter. Invalid interface	4 (Error)	A management station attempted to add an LLC filter for an interface other than Ethernet or Hfc. Retry the add with the correct interface number.
F511.2	Bridge Api. Failed to Read IP filter stats. Invalid interface.	2 (Alert)	A management station attempted to add an IP filter for an interface other than Ethernet or Hfc. Retry the add with the correct interface number.

Code	Event Log Messages	Level	Cable Modem Actions
F511.3	Bridge Api. Failed Set IP Spoof Enroll. Can't get memory to clear table.	2 (Alert)	An attempt was made to set docsDevFilterCpeEnroll to -a new value. CM could not get enough memory to make necessary modifications to docsDevFilterCpeTable entries. Contact your vendor.
F511.4	Bridge Api. Failed Set IP Spoof Max. New Max won't hold existing filter entries.	4 (Error)	An attempt was made to decrease the size of docsDevFilterCpeMax and there were already more entries in docsDevFilterCpeTable than the new max would hold. Action: Delete filters from docsDevFilterCpeTable and retry decrease of docsDevFilterCpeMax.
F511.5	Bridge Api. Failed to get Ip Spoofing Filter Entries. Can't allocate memory.	2 (Alert)	An attempt was made to query the system for docsDevFilterCpeTable entries. There was not enough system memory to return the entries. Contact your vendor.
Driver			
H501.1	HFC: Shutting Upstream Down	7 (Info)	
H501.2	HFC: Shutting Downstream Down	7 (Info)	
H501.3	HFC: US BABBLE PHY ERROR	3 (Critical)	
H501.4	HFC: LOST TRC SYNC- trying to recover	3 (Critical)	
H501.5	HFC: TRC RECOVERY FAILED	3 (Critical)	
H501.6	HFC: TRC LOCK Recovery OK	7 (Info)	
H501.7	HFC: T2 Timer Expired	3 (Critical)	
H501.8	HFC: T4 Timer Expired	3 (Critical)	
H501.9	HFC: T1 Timer Expired	3 (Critical)	
H501.10	HFC: Bandwidth request failure	5 (Warn)	
H501.11	HFC: FEC LOCK recovery failed	3 (Critical)	
H501.12	HFC: FEC LOCK recovery OK	7 (Info)	
H501.13	HFC: Invalid UCD	3 (Critical)	
H501.14	HFC: Lost FEC LOCK - trying to recover	3 (Critical)	
H501.15	HFC: FEC LOCK recovery OK	7 (Info)	
H501.16	HFC: FEC LOCK recovery failed	3 (Critical)	
H501.17	HFC: UCD Minislot size change	7 (Info)	
H501.18	HFC: UCD Symbol rate change	7 (Info)	
H501.19	HFC: UCD Invalid minislot size	3 (Critical)	
H501.20	HFC: UCD Invalid symbol rate	3 (Critical)	
H501.21	HFC: UCD Invalid upstream freq	3 (Critical)	
H501.22	HFC: UCD Invalid actual preamble length	3 (Critical)	

Code	Event Log Messages	Level	Cable Modem Actions
Registration			
I500.0	Registration Completed	7 (Info)	
I502.0	Error transmitting Registration Request message	4 (Error)	Time out and the board will reset
I503.0	Cable Modem is OPERATIONAL	7 (Info)	No action taken
I504.0	REG-RESP Invalid Vendor ID Len, CONTINUE	4 (Error)	Ignore and continue reading the next bytes
I505.0	Registration RSP with COV failure	1 (Emerg)	Resend Reg-Req up to 3x before power cycle
I506.0	Retried 2nd time and REG-RSP is still failed. Retransfer TFTP config	1 (Emerg)	Retransfer TFTP Config
I507.0	Retried 3 rd time and REG-RSP is still failed. Power Cycle	1 (Emerg)	Power Cycle
I508.0	Registration RSP with authentication failure	1 (Emerg)	Resend Reg-Req up to 3 times before power cycle
I509.0	TFTP Server Provisioned Modem Address format invalid in length	4 (Error)	Ignore and continue reading the next bytes
I509.1	TFTP Server Timestamp format invalid in length	4 (Error)	Ignore and continue reading the next bytes
I510.0	***BOOTING [sw_version]***	7 (Info)	
I511.0	Reset due to SNMP docsDevResetNow	7 (Info)	
Miscellaneous			
M500.0	Startup pipe cannot be retrieved	1 (Emerg)	When time out, the board will reset
M500.1	Startup pipe cannot be created	1 (Emerg)	When time out, the board will reset
M503.0	Unable to initialize HTTP Server, no HTML supported	5 (Warn)	No action taken
M503.1	Unable to initialize UI, no HTML supported	5 (Warn)	No action taken
M504.0	Unable to create or start WDT. No automate Reset supported	5 (Warn)	When Timeout, the board will reset
M505.0	Unable to create SnmpDelayReset task	5 (Warn)	
M510.0	ReadFromFlash - flash Semaphore NULL, cannot access flash	1 (Emerg)	
M510.1	WriteToFlash - flash Semaphore NULL, cannot access flash	1 (Emerg)	
M550.0	Hash Table failed to allocate memory for entries.	1 (Emerg)	Attempt was made to create a hash table. System did not have enough memory. Contact your vendor.
M550.1	Hash Table failed to allocate memory for hash table.	1 (Emerg)	Attempt was made to create a hash table. System did not have enough memory. Contact your vendor.
M550.2	Hash Table failed to add entry. Hash Key out of table range.	1 (Emerg)	System attempted to hash into a hash table. Hash key that was calculated was out of the table range. Contact your vendor.
M550.3	Hash Table failed to delete entry. Hash Key out of table range	1 (Emerg)	System attempted to hash into a hash table. Hash key that was calculated was out of the table range. Contact your vendor.
M550.4	Hash Table failed to delete entry. Entry not found	4 (Error)	An attempt was made to delete an entry from a hash table and the entry did not exist in the table.

Code	Event Log Messages	Level	Cable Modem Actions
M550.5	Hash Table can't allocate memory to resize table.	1 (Emerg)	An attempt was made to change the size of a Hash Table. The system was not able to allocate enough memory to perform the operation. Contact your vendor.
M550.6	Hash Table failed to resize table. Current entries > new size.	4 (Error)	An attempt was made to decrease the size of an existing hash table that has more entries than the new size will hold. If possible delete some of the entries and try the operation again.
M551.0	***** REACHED MAX ENTRIES, LOG IS WRAPPED *****	7 (Info)	No action taken
Acquisition			
T500.0	Acquired UpstreamSUCCESS	7 (Info)	
T501.0	Acquired Downstream [Curr Freq in Hz]SUCCESS	7 (Info)	
T502.0	Scan Downstream [Curr Freq in Hz] for [enum] time with status [status enum]	8 (Debug)	No action taken
T503.0	Acq DS [Curr Freq in Hz] with status [status string]	8 (Debug)	No action taken
T503.1	Acquire US with status [status string] powerLevel [value] tempSid [SID]	8 (Debug)	No action taken
T503.2	Move Downstream with status [status]	8 (Debug)	
T504.0	Both Downstream & Upstream have been changed	8 (Debug)	No action taken
T505.0	Acquired Upstream with status [status enum]	8 (Debug)	No action taken
T506.0	Downstream Frequency has been changed	8 (Debug)	No action taken
T507.0	Received Async Error [UCC Type]	2 (Alert)	Shutdown3220 and reset the board.
T508.0	Fail to Acquire Upstream. Error Stats [statnum], Retry [num]	4 (Error)	After received a UCC-REQ to change upstream, attempt to acquire upstream with new data and it failed. Keep acquiring upstream until success
T509.0	Acquired DS with status %, DS Freq %d, US Id %d",	8 (Debug)	No action taken
T510.0	Acquire DS after RR Chg with status [status]	8 (Debug)	No action taken
Unit Update			
X500.0	Attempting Unit Update.	7(Info)	No action needed.
X501.0	Can't allocate memory to read UU data from flash	2(Alert)	Continue using current image. CM is out of memory. Try rebooting CM. If problem persists contact your vendor.
X501.1	Can't read Unit Update data from flash.	4(Error)	Update will complete. If problem persists contact your vendor
X501.2	Can't write Unit Update data to flash.	4(Error)	Update will complete, but value for docsDevSwOperStatus may be incorrect after CM reboots. If problem persists contact your vendor.

Code	Event Log Messages	Level	Cable Modem Actions
X501.4	Provisioned Unit Update skipped. Image is current.	7(Info)	CM did not perform a provisioned Unit Update because it is already running the image it was told to download. No Action needed.
X501.5	Unable to create UnitUpdate Task.	2(Alert)	Update failed. CM was unable to create the task to do the update. Reboot CM and try the update again. If problem persists contact your vendor.
X501.6	Unit Update Failed. Reached Max Retries.	4(Error)	Unit Update failed. See previous event log messages for explanation of failure.
X501.7	Unable to write image file to flash	4 (Error)	Continue using current image file. Possibly send somebody over to troubleshoot flash.
X501.8	Unit Update From SNMP..... SUCCESS	7(Info)	No action taken
X501.9	Unit Update From CLI..... SUCCESS	7(Info)	No action taken
X501.10	Unit Update From Config File..... SUCCESS	7(Info)	No action taken
X501.11	Unit Update Image length is invalid. Length = [length]	4 (Error)	Continue using current image. Unit update failed. Image is too large, probably bad image file. Obtain new image file.
X501.12	Unit Update MD5 Checksum Failed	4(Error)	Continue using current image. Update failed. Image is corrupted. Get new copy of image file.
X501.13	Could not write App image to flash.	2(Alert)	Continue using current image. Update failed. System could not write the new image to the flash. Try operation again. If problem persists, contact your vendor.
X501.14	Unit Update: Could not write Header to flash.	2(Alert)	Continue using current image. Update failed. System could not write the new image header to the flash. Try operation again. If problem persists, contact your vendor.
X501.15	Unit Update: Could not write Bootrom to flash..	2(Alert)	Update failed. System could not write the new bootrom to flash. Try operation again. If problem persists, contact your vendor.
X501.16	Unable to Transfer Image File for Unit Update.	4(Error)	Continue using current image. CM was unable to transfer the new image from the server. Check for network problems, that file exists, that docsDevSwServer is the correct address of the Software Server and retry the operation.
X501.17	Select timed out trying to get Image file for Unit Update.	4(Error)	Continue using current image. CM was unable to transfer the new image from the server. Check for network problems, that file exists, that docsDevSwServer is the correct address of the Software Server and retry the operation
X501.18	Unit Update, Unable to allocate memory for image.	2(Alert)	Continue using current image. Update failed. CM is out of memory. Try rebooting CM. If problem persists contact your vendor.
X501.19	Unit Update – Error retrieving image file.	4(Error)	Continue using current image. CM was unable to transfer the new image from the server. Check for network problems, that file exists, that docsDevSwServer is the correct address of the Software Server and retry the operation.

Code	Event Log Messages	Level	Cable Modem Actions
X501.20	Unit Update, Unable to allocate memory for Bootrom image..	2(Alert)	Continue using current image. Update failed. CM is out of memory. Try rebooting CM. If problem persists contact your vendor.
X501.21	Unit Update - Error retrieving image file.	4(Error)	Continue using current image. CM was unable to transfer the new image from the server. Check for network problems, that file exists, that docsDevSwServer is the correct address of the Software Server and retry the operation.
X501.22	Unit Update - Read wrong number of bytes for Bootrom.	4(Error)	Continue using current image. Update failed. The image file is most likely corrupt. Obtain a new copy of the image file.
X501.23	Unit Update failure. No data read from file.	4(Error)	Continue using current image. CM was unable to transfer the new image from the server or the image is corrupt. Check for network problems, that file exists, that docsDevSwServer is the correct address of the Software Server and retry the operation. Obtain a new copy of the image file.
X501.24	Unit Update - error reading header from [filename]	4 (Error)	Continue using current image. Update failed. CM was unable to transfer the new image from the server or the image is corrupt. Check for network problems, that file exists, that docsDevSwServer is the correct address of the Software Server and retry the operation. Obtain a new copy of the image file.
X501.25	Unit Update - error reading image file header.	4 (Error)	Continue using current image. Update failed. CM was unable to transfer the new image from the server or the image is corrupt. Check for network problems, that file exists, that docsDevSwServer is the correct address of the Software Server and retry the operation. Obtain a new copy of the image file.
X501.27	Unit Update - can't update from <image name> to <image name>	4 (Error)	Continue using current image file. Illegal update. Can't go from installed image to requested image. Either image is for wrong product, or an illegal downgrade was attempted.
X501.28	Unit Update - can't update to <product model> image on product model>	4 (Error)	Continue using current image file. Illegal update. Can't go from installed image to requested image. Image is wrong image for this product.
X501.29	No need to update to <name of image> - same image	7 (Info)	No action taken. Attempted to update to image that is already loaded on CM.
X501.30	Can't allocate memory to write SNMP Uu Parameters to Flash.	4(Error)	See previous messages to determine if Update completed. Value of docsDevSwOperStatus may be incorrect after reboot. If problem persists contact your vendor.
X501.31	Unable to save SNMP Uu Parameters to Flash.	4(Error)	See previous messages to determine if Update completed. Value of docsDevSwOperStatus may be incorrect after reboot. If problem persists contact your vendor.

Code	Event Log Messages	Level	Cable Modem Actions
X501.32	Unit Update. Can't perform Unit Update, Unit Update already in progress.	4(Error)	SNMP attempted to start a Unit Update while another Unit Update was already in progress.
X501.33	SNMP Unit Update was in progress before reboot. Retrying Update.	4(Error)	SNMP was attempting a Unit Update when the CM rebooted for some reason. CM will reattempt the Unit Update.

Abbreviations and Acronyms

CMTS	Cable Modem Termination System
DHCP	Dynamic Host Configuration Protocol
FEC	Forward error correction
IP	Internet Protocol
LAN	local area network
LED	light-emitting diode
PC	personal computer
QAM	quadrature amplitude modulation
RF	radio frequency
SNMP	Simple Network Management Protocol
TCP/IP	Transport Control Protocol/Internet Protocol
TFTP	Trivial File Transfer Protocol
TRC	Technical Response Center

